



THS/PH21N-FB



DETECTION OF VERY TINY METAL PARTICLES ON TABLETS WITH AUTOMATIC REJECTION



ULTRA HIGH SENSITIVITY METAL DETECTOR

- Ultra high sensitivity to all magnetic and non-magnetic metals, including stainless steel
- AISI 316L stainless steel construction
- 500 product profiles, selectable by local programming or network software
- 10,000 storable events
- High-contrast graphic display
- Quick Access key for fast programming of user parameters

FLAT CONVEYOR INSPECTION SYSTEM

- Integrated controls for line speed and rejection
- High immunity to environmental interference
- Automatic learning & tracking of product effect
- Easy to maintain and inspect
- Digitally adjustable belt speed
- Automatic ejection management with synchronization of the product transit
- Verification of the successful ejection of the contaminated product
- Applications: effervescent tablets



www.maydokimloaiceia.vn



Quality Control at its finest

SPECIFIC INSPECTION AGAINST TINY METAL PARTICLE CONTAMINATION IN EFFERVESCENT TABLETS



FULL COMPLIANCE WITH PHARMACEUTICAL SECTOR REGULATIONS

- 1 THS/PH21N Metal Detector
- 2 Ejector
- 3 Ejector
- 4 Bin full photocell
- 5 Color LED lamp and buzzer
- 6 Emergency buttons
- 7 Control panel
- 8 Synchronization photocell
- 9 Motor

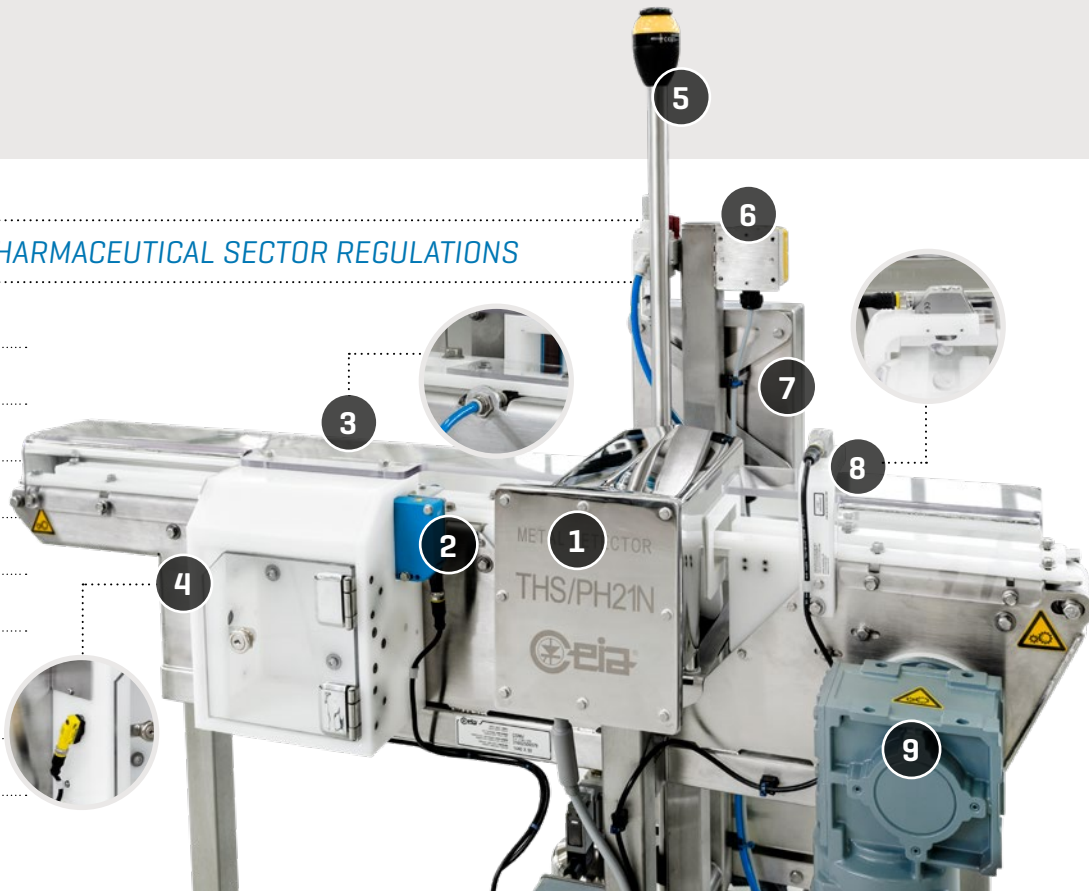
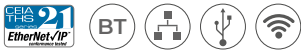

MECHANICAL DRAWINGS

FRONT

LATERAL

TOP

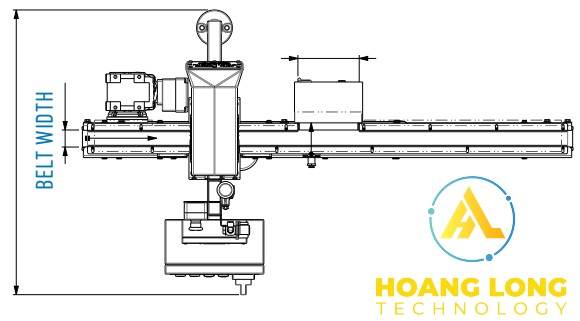
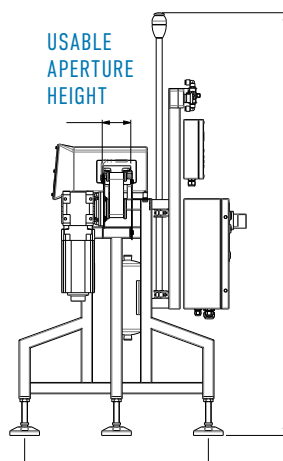
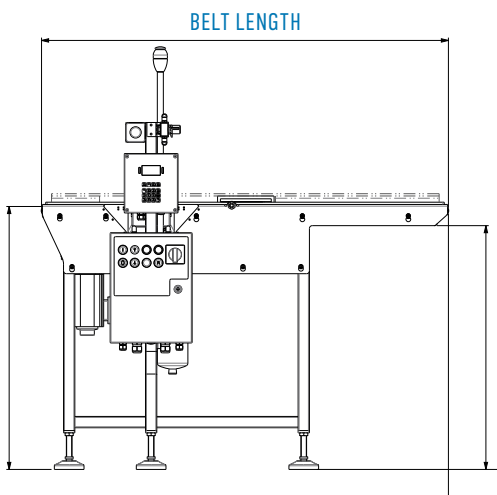

HOANG LONG TECHNOLOGY
Always for your product quality



HOANG LONG TECHNOLOGY CO., LTD. 468 Le Hong Phong Str, Dist.10, Ho Chi Minh City
Hotline: 0907 636 889 Email: h0anglongtechnology@gmail.com

www.maydokimloaiceia.vn

