



IQ4 BottleChek- Metal Detection

Designed for the Pharmaceutical Industry

Product Highlights

- Designed for the inspection of bottles and vials
- Easily integrates into any production line for side-by-side transfers
- Fail-safe eject mechanism eliminates errors with reject confirmation and bin full alarm
- Exceptional stability to extreme vibration and Auto Head Balance for improved sensitivity
- Performance Validation System to ensure accuracy and proper performance
- True variable frequency detection easily adapts to new product and packaging in seconds to obtain the best achievable results for your product and environment

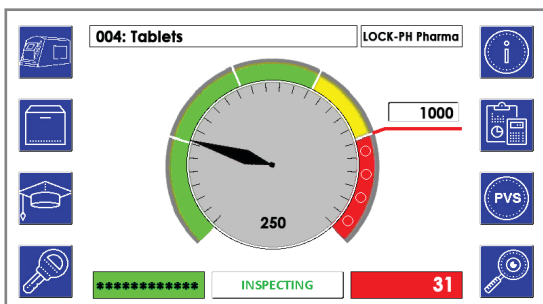

7" Touchscreen with a new easy to use interface

The new big 7" touchscreen offers 33% more space than previous generation metal detectors making operations simple.



Auto Learn Provides Simple and Fast Set-up

The IQ4 BottleChek will automatically set-up and store 200 different pre-sets, adjusting for product effect and loose material as the product passes through the system.



Easy to Clean and Maintain

The IQ4 BottleChek is fully GMP compliant and is made to be easy to clean and maintain with no dust traps.

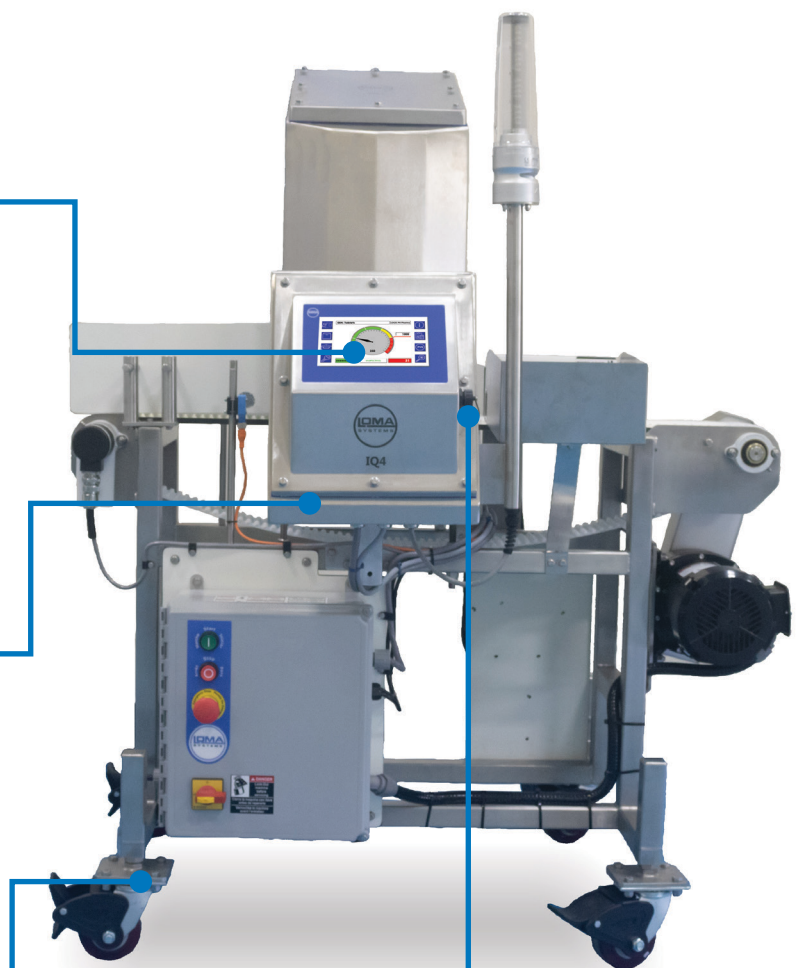

External USB Port for Data Reports

Each unit is supplied with an external USB port to download data for secure storage and distribution in pdf or other formats. Wired or wireless ethernet and SCADA capability are available.

Technical Specification

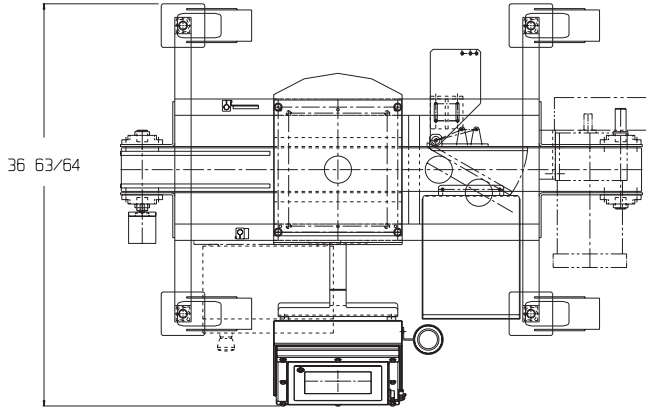

Material of Construction	304 Stainless Steel
Line Height	914mm
System Length	1829mm
Standard Belt Width	102mm Modular Belt
Speed	Up to 30 meters per minute
Environment	-10° to 60°C / 14° to 140°F; Humidity 0-95% RH
Washdown Protection	IP69K
Supply Voltages	88-264V AC, 47-63Hz
Ethernet Capability	Yes
USB Capability	Yes

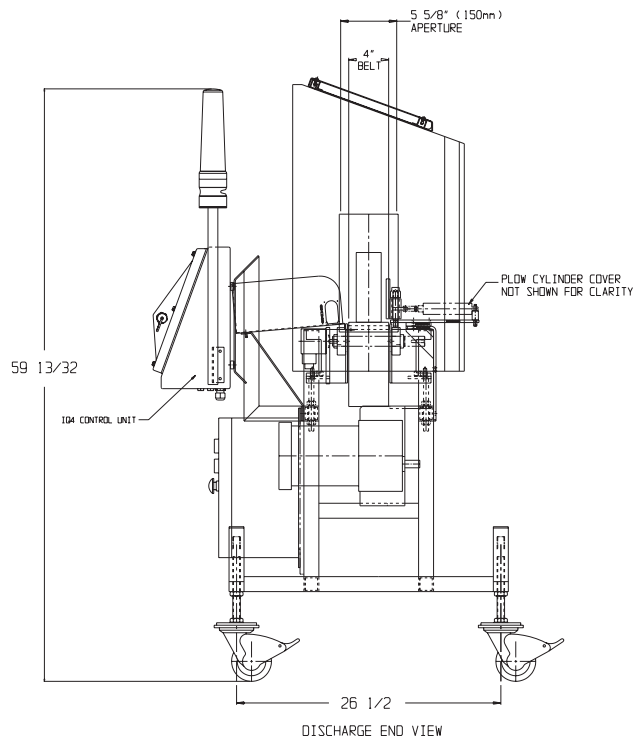
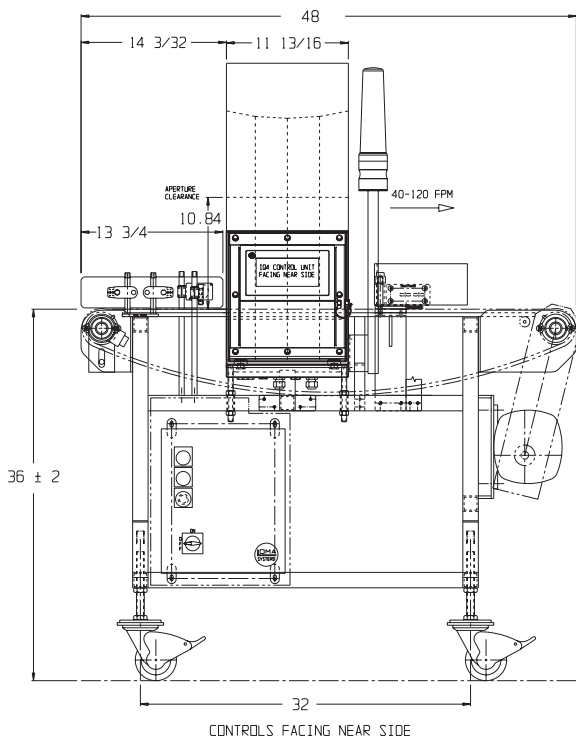

All dimensions in inches

Automatic Reject Options

The IQ4 BottleCheck can be configured to suit a variety of different product applications. It is available in various configurations including:

- Plough (standard)
- Pusher
- Air-blast



**HOANG LONG
TECHNOLOGY**

Always for your product quality

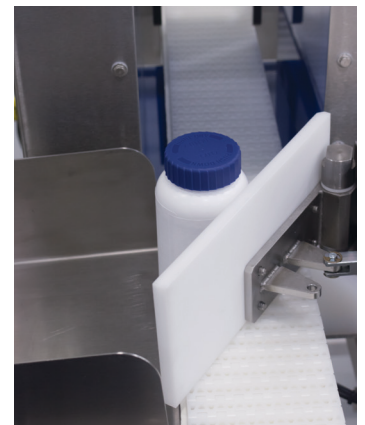

An **ITW** Company

Loma Systems is a registered trademark of Illinois Tool Works Inc. (ITW). Other names, logos, icons and marks identifying our products and services referenced herein are trademarks of ITW and may not be used without the prior written permission of ITW. Other product and company names listed are trademarks or trade names of their respective companies. Copyright © 2016 Illinois Tool Works Inc. All rights reserved. All of the specifications shown in this document are subject to change without notice.

www.congnghehoanglong.com

Hotline: 0907 686 889 | Email: hoanglongtechnology@gmail.com

Metal Detection | Checkweighing | X-Ray Inspection

In association with

