



# IQ4 LOCK-PH Pharmaceutical - Metal Detection

Designed for the Pharmaceutical Industry

## Product Highlights

- Designed for inspecting tablets and capsules after the tablet press and de-duster process
- Throughput up to 30,000 tablets / capsules per minute
- Best in class calibrated detection levels from 0.22mmFE, 0.28mmNFE, 0.37mm St/St (optimum performance)
- Gas strut stand frame offering exceptional manoeuvrability making it convenient for use with all leading tablet presses and encapsulation machines
- Four password protected security levels are provided for Operators, Supervisors, Engineering and Administration with unique individual access controls, with specific user preferred languages
- Full IQ, OQ, PQ validation documents and certification
- Design and construction compliant to NEMA 4X / IP66

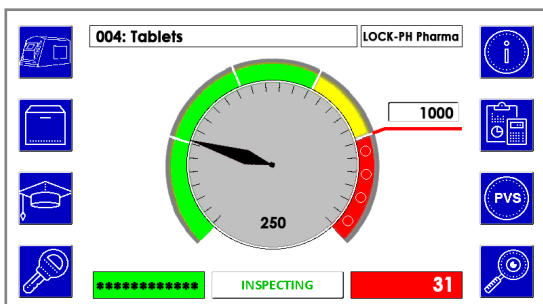

### 7" Touchscreen with a new easy to use interface

The new large standard 7" colour touchscreen ensure simplicity of operation and setting up of products and changeovers can be achieved effortlessly.



### Digitally embedded self calibration tool

LOMA's unique software can constantly monitors the frequency and signal to continuously optimise the units detection performance. Additionally, the unit provides a easy to view health check screen so you always ensure your machine is working perfectly.



### Auto Learn Provides Simple and Fast Set-up

The LOCK-PH will automatically set-up and store 200 different pre-sets, calibrating for product environment or effect as product passes through the metal detector.



### Easy to Clean and Maintain

The LOCK-PH is fully GMP compliant and is made with a mirror polished finish with no dust traps.

# Technical Specification

Material of Construction	304 polished Stainless Steel with 316 mirror polished Stainless Steel reject and all parts are FDA, EU approved and certificated.
Single Frequency	1MHZ - and staggered frequency option for multiple machines
Supply Voltages	110 - 250V AC 50/60Hz
Power Consumption	20VA
Temperature Range	10°C TO 35°C (14°F to 95°F)
Humidity	0 to 95% Relative Humidity (Non-condensing)
Environment	IP66
PVS Enabled	Yes
Ethernet Capability	Yes
USB Capability	Yes

## IQ4 LOCK-PH SYSTEM 95x22 HEAD APERTURE

Standard Line

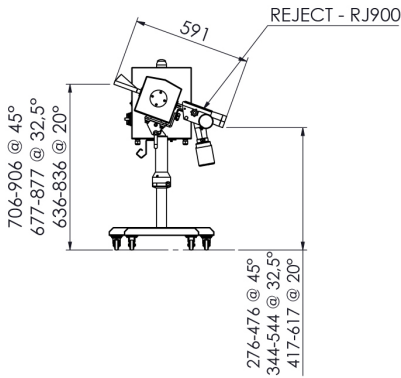

Low Line

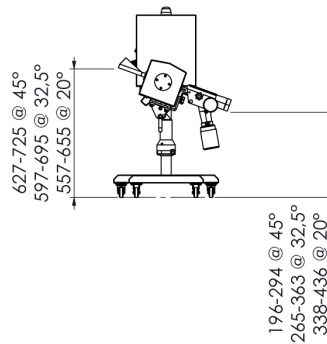

High Line

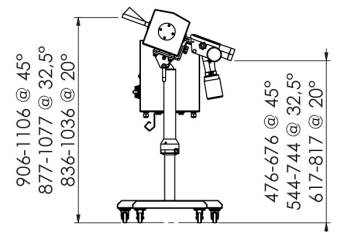

## IQ4 LOCK-PH SYSTEM 95x38 HEAD APERTURE

Standard Line

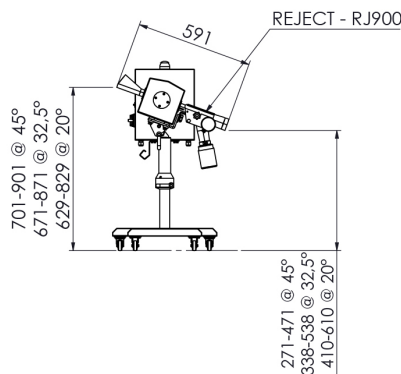

Low Line

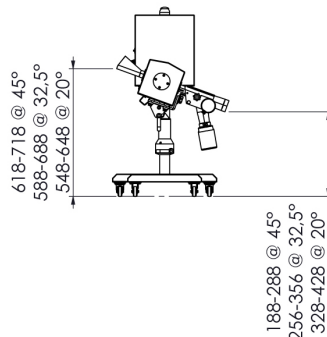

High Line

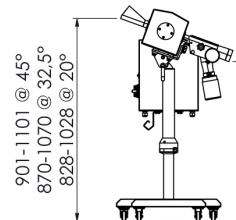

All dimensions in mm, drawing 's based on Insight model. LOCK-PH drawing available on request.

## Automatic Reject Options

The IQ4 LOCK-PH Pharmaceutical can be supplied as standard with either a 316 stainless lift flap or diverter reject with square or round outlet. WIP dust tight for de-duster applications are also available.



An ITW Company

Loma Systems is a registered trademark of Illinois Tool Works Inc. (ITW). Other names, logos, icons and marks identifying our products and services referenced herein are trademarks of ITW and may not be used without the prior written permission of ITW. Other product and company names listed are trademarks or trade names of their respective companies. Copyright © 2018 Illinois Tool Works Inc. All rights reserved. All of the specifications shown in this document are subject to change without notice.

[www.congnghehoanglong.com](http://www.congnghehoanglong.com)

Hotline: 0907 686 889 | Email: [hoanglongtechnology@gmail.com](mailto:hoanglongtechnology@gmail.com)

**Metal Detection | Checkweighing | X-Ray Inspection**

In association with

