

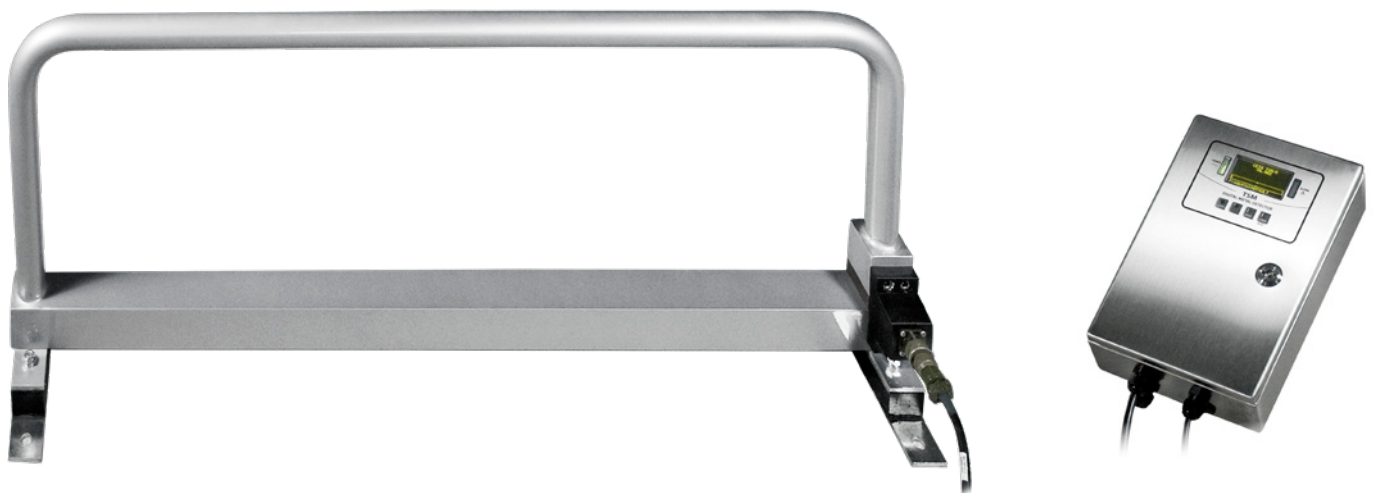

TSM-D

Quality Control at its finest

TUNNEL METAL DETECTOR FOR INDUSTRIAL USE



PROBE

ELECTRONIC
CONTROL UNIT

FEATURES

- Detection of both magnetic and non-magnetic metals
- High immunity to environmental interference
- Installed without cutting conveyor belt
- Digital Programming
- Very high reliability
- IP65 main unit and probe



www.maydokimloaiceia.vn



Hotline: 0907 686 889 - Email: hoanglongtechnology@gmail.com



The CEIA TSM-D digital Metal Detector is suitable for intercepting magnetic and non-magnetic metal fragments of medium to large dimensions in industrial, textile, chemical, mining, foodstuffs and other products, both for quality control and machinery protection.

The product to be inspected is carried on a conveyor belt through the Detector Probe, which is connected to the Electronic Control Unit. The **TSM-D Metal Detector** probe unit can be opened up, thereby allowing installation on conveyor belts without cutting them. Detection sensitivity and other operational settings can be pre-selected digitally using function keys and alphanumeric display.

The **TSM-D Metal Detector** features extremely robust construction, which allows its installation in difficult environments, both inside and outside, without reduction in its operational features. Digital processing of signals guarantees the highest immunity to external electromagnetic interference. The **TSM-D Metal Detector** is tested to conform to Electrical Safety and Electromagnetic Compatibility standards required for the CE mark.

Specifications

DETECTION FUNCTIONS	Adjustable sensitivity
	Interception speed programmable according to applications [2 to 250 m/min]
	Digital programming with alphanumeric display
	Visual and acoustical indicator
	Built-in self-diagnosis system
	Built-in settings memory without backup battery
INPUTS / OUTPUTS	Programmable Alarm Relay: rating 30 Vac, 2.5A
	Encoder/Reset Input
	Standard bluetooth connectivity
POWER SUPPLY	100-240 Vac, 50/60 Hz, 1.5A max
ENVIRONMENTAL REQUIREMENTS	Operating temperature: -10 to +55 °C
	Relative humidity: 0 -95% (without condensation)
APPLICATIONS	Product Quality Control and protection of machinery in the following industries: <ul style="list-style-type: none"> • Textiles • Concrete • Timber • Chemicals • Mining • Paper • Foodstuffs • Clay
CERTIFICATION AND CONFORMITY	Conforms and is tested to European standards required for the CE mark
	Complies with EC regulations and international standards relating to electrical safety and electromagnetic compatibility
OTHER	Dimensions of main unit and probe: see drawing and table Length of cable connecting main unit and probe: standard 3m, others on request. Conforms and is tested to European Standards required for the CE mark

Dimensions

PROBE

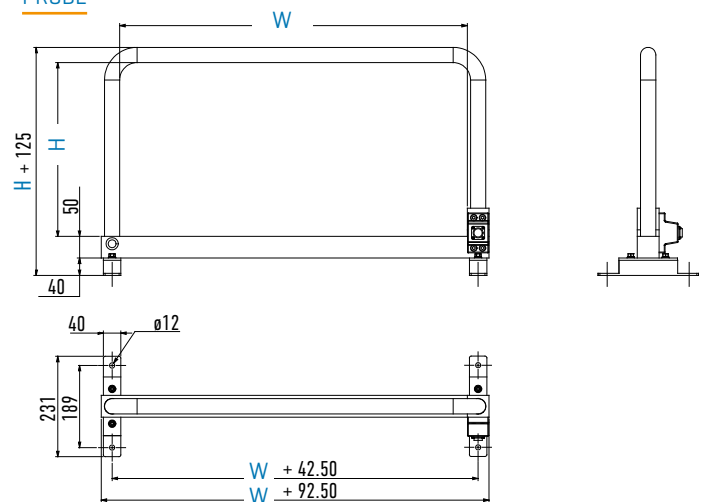

W	500 ÷ 1500 in 100 mm increments	Dimensions of standard models [mm]
H	200 ÷ 700 in 50 mm increments	Other sizes on request

ELECTRONIC CONTROL UNIT

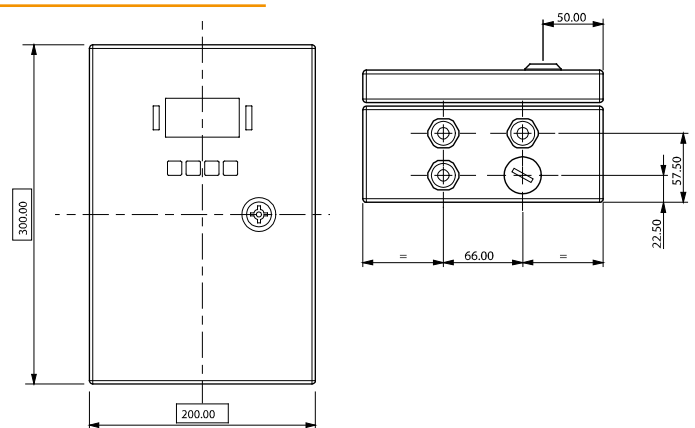

HOANG LONG TECHNOLOGY CO., LTD

Hotline: 0907 686 889 - E-mail: hoanglongtechnology@gmail.com

www.maydokimloaiceia.vn



HOANG LONG TECHNOLOGY
 Always for your product quality

Official Distributor in Vietnam

CEIA reserves the right to make changes, at any moment and without notice, to the models, their accessories and options, to the prices and conditions of sale. DP014K0002v3000uUK-65732

