

SDT



HOANG LONG
TECHNOLOGY

Always for your product quality

ADVANCED DIGITAL METAL DETECTOR FOR RECYCLING INDUSTRY

ULTRA HIGH
SENSITIVITY
TO ALL METALS

HIGHEST
IMMUNITY TO
ENVIRONMENTAL
INTERFERENCE



KEY FEATURES

- **Ultra high Sensitivity** to all magnetic and non-magnetic metals, including stainless steel
- **Openable AISI 316** stainless steel construction system
- **Compact** and **robust construction**
- **High immunity** to environmental interference
- **Wide Detection Speed range**, from 1 up to 600 m/min
- **Easy installation** and **setting on existing conveyor** without belt opening
- **Internal self-diagnosis system**
- **Easy to read, high-contrast graphic display**

APPLICATIONS

- PAPER
- WOOD
- TEXTILE
- GARMENT
- PLASTIC
- RECYCLING
- RUBBER
- CHEMICAL
- RUBBER
- MINING
- CEMENT



www.maydokimloaiceia.vn



QUALITY CONTROL AT ITS FINEST

The **CEIA SDT digital Metal Detector** is suitable for intercepting magnetic and non-magnetic metal fragments of small to medium dimensions in recycling industrial, textile, chemical, mining, foodstuffs and other products, both **for quality control** and **machinery protection**.



SPECIFICATIONS

GENERAL FEATURES	Adjustable sensitivity with wide dynamic range (0-299)	
	Interception speed programmable according to its application	
	Digital programming with OLED graphic display	
	Internal data logging with data and timestamp for Quality Control	
	Autolearn function for automatic setting of the maximum sensitivity in dry and wet conditions	
	Built-in self-diagnosis system	
	Permanent settings memory without battery back-up	
STRUCTURES	Material	Electronic unit: AISI 316 Stainless steel Probe: AISI 316 Stainless steel
	Protection degree	IP65
POWER SUPPLY	Voltage	100-240 V- single phase - 50/60 Hz
	Current	0,64 A max
PROGRAMMING	Type	Local: Through built-in keyboard Remote: BT Wireless
	Data capabilities	Internal memory 1000 events 20 products
SIGNALLING	Audible	Internal buzzer
	Visual	Graphic display with bar-graph indication Bright indicators on Control Panel RED: Alarm or fault GREEN: Line present
SECURITY AND SAFETY	Programming access	2 access levels: Operator and Supervisor
	Galvanic isolation of line voltage	
	Low operating voltage	No danger for the operator
	In accordance with international standards of safety and radio interference	
CONTROL INPUTS	Connection for	Alarm reset or Encoder input
	BT Wireless interface	Built-in
OUTPUTS	1 programmable relay	Alarm relay
ENVIRONMENTAL DATA	Temperature	Working: 0 - +50 °C Environmental: -10 - +55 °C Storage: -25 ÷ +55 °C
	Relative humidity	5 - 90 %, without condensation

GENERAL DIMENSIONS (mm)

UW useful width	UH useful height	DL
600, 800, 1000, 1300	350	500
	500	
	700	700

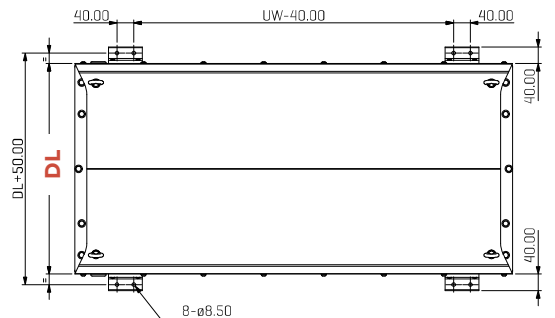
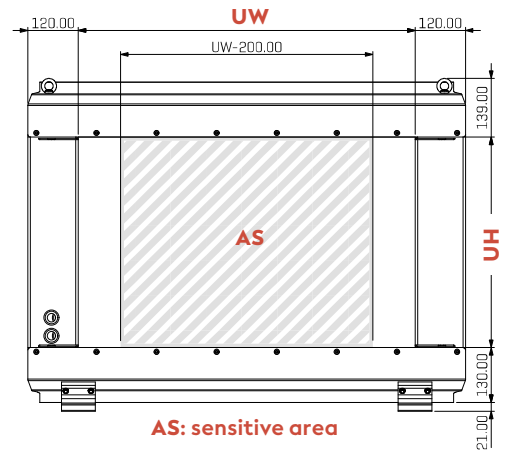
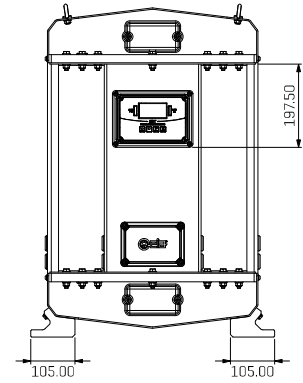

www.maydokimloaiceia.vn



Hotline: 0907 686 889 • Email: hoanglongtechnology@gmail.com

CEIA reserves the right to make changes, at any moment and without notice, to the models (including programming), their accessories and options, to the prices and conditions of sale. DPO14K0003v2000hUK - 117991 (2023)