



# X5 Bulkflow: X-ray Inspection System

Designed for Food & Packaging Industries

X-Ray  
Detection

## Product Highlights

- X-ray system designed for inspection of loose, unpackaged free-flowing product such as nuts, dried fruit, lentils, pulses, poultry and meat.
- Unique geometry provides excellent detection of all metals, bone, glass and dense plastics
- 0.4 mm diode array with Adaptive Array Technology (AAT)
- Reject options include Single Flap, Dual Flap, Multi-Flap (4) or Carriage Retractable Band
- Built for 24/7 operation with pass key Protective Set-up for added security and control
- Windows 10 PC with Ethernet and USB Port

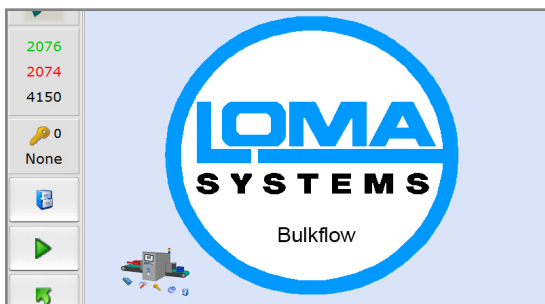

### Easy to Use Intuitive Full Color Touchscreen

The X5 Bulkflow includes an Icon driven full colour touchscreen control interface which eases set-up of the system to suit a particular product



### Reject options designed to minimize product wastage on rejection

The reject station can be specified as a single-flap, dual-flap, multi-flap or as a carriage retract band, depending on the production application.

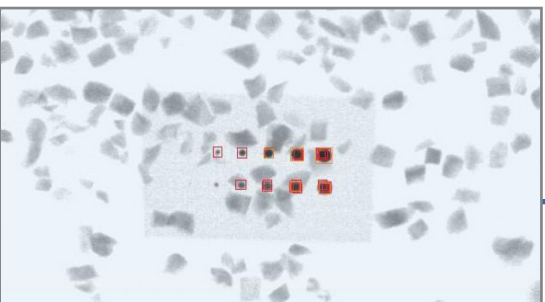

### Excellent detection of all metals, stone, ceramic, glass and bone

The unique detection geometry and the 0.4 mm detector array with AAT provide an unrivalled detection performance in loose flowing product



### Environment Ready, IP66 Independently Rated

Fully IP66 rated and designed for low pressure wash-down, the X5 Bulkflow is hygienic and with a quick release belt, is easy to clean

# Technical Specification

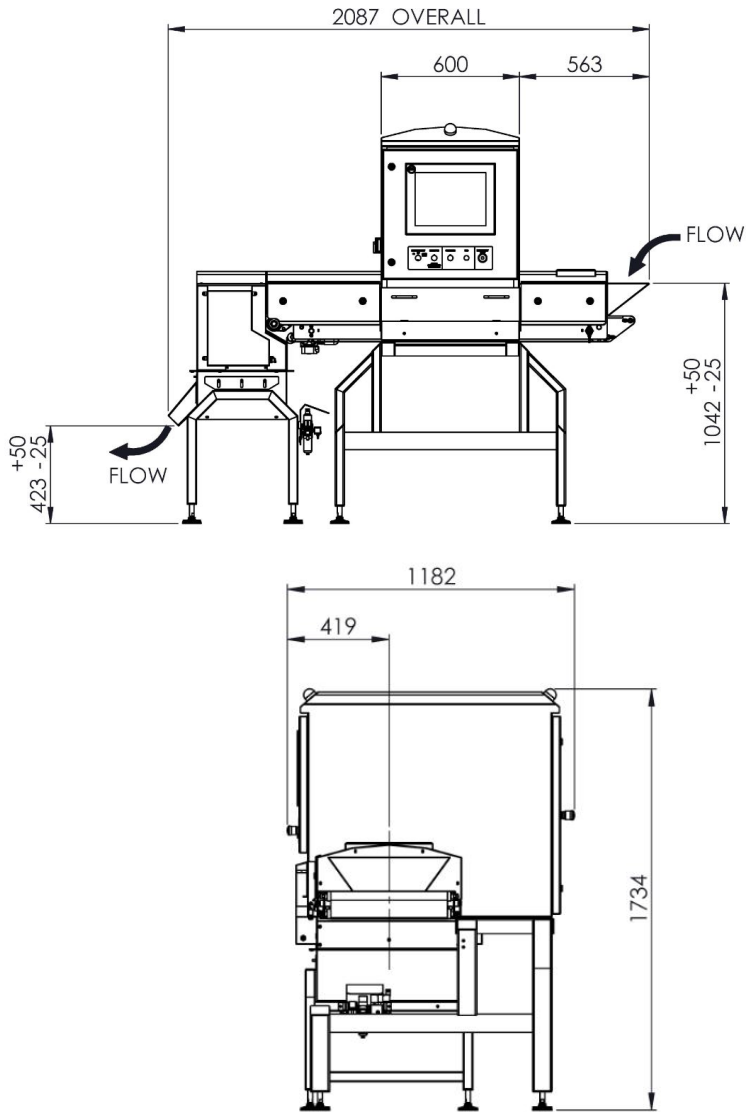

Finish	304 Stainless Steel (Brushed)
System Length	2087 mm
Nominal Belt Line Height Options	750   800   850   900   950   1000 +50/-25 mm adjustment
Belt Width	300 mm   500 mm
Product Height (maximum)	up to 60 mm
Belt Speed (maximum)	30 - 80 m/min (dependent upon belt width and detector pitch)
X-Ray Output	200W (40kV 5 mA)
IP Rating	IP66
Power Requirements	230V AC, 50Hz or 110v AC 60Hz, Single Phase Mains
Cooling	Vortex Cooler (requires compressed air connection)
Operating Environment	10 to 35 °C (50 - 95 °F)
	2 to 10 °C (32 - 50 °F) with automatic cabinet warm-up enabled
X-Ray Safety	Leakage less than 1 µSv/h
Algorithms (Mass Flow Mode)	2 x Image Processing 5 x Contaminant Detection 3 x Product Integrity
Reporting	Event, Batch, Shift, PVS
Data Retrieval	Via USB, Ethernet

Typical system dimensions shown (in mm). Dimensions are dependent on system configuration.

## Automatic Reject Options

The X5 Bulkflow comes complete with one of the following reject options:

- Single-Flap
- Dual-Flap
- Multi-Flap (4 flaps)
- Carriage Retract Band

Please consult LOMA for a better understanding of which reject is suitable for which application.



An ITW Company

Loma Systems is a registered trademark of Illinois Tool Works Inc. (ITW). Other names, logos, icons and marks identifying our products and services referenced herein are trademarks of ITW and may not be used without the prior written permission of ITW. Other product and company names listed are trademarks or trade names of their respective companies. Copyright © 2019 Illinois Tool Works Inc. All rights reserved. All of the specifications shown in this document are subject to change without notice.

[www.congnghekiemtra.vn](http://www.congnghekiemtra.vn)

Hotline: 0907 686 889 | Email: [hoanglongtechnology@gmail.com](mailto:hoanglongtechnology@gmail.com)

**Metal Detection | Checkweighing | X-Ray Inspection**

In association with



XSBLK\_893201905