



# X5C - Compact X-ray Inspection System

Designed for Food & Packaging Industries

X-Ray  
Detection

## Product Highlights

- For inspecting retail-packed convenience food, ready meals, and small end-of-line packaged goods up to 280 mm wide by 110 mm high
- Good detection of all metals, bone, glass and dense plastics, even in foil trays or metalized film
- Robust stainless steel construction with 1000 mm machine length
- Colour touchscreen control interface including multi-level password access and data logged events for traceability (designed to help comply with 21CFR Part 11 requirements)
- Good set of inspection features for contaminant detection, product integrity checks and quality assurance reporting
- IP66 ingress rating and tool-free belt removal for low-pressure wash-down

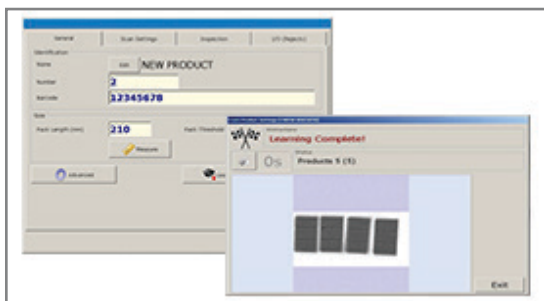

### Get Inspecting Fast with Loma's Product Learn Wizard

A set-up wizard automatically optimises the X5C for each product type and allows you to learn or switch to new products within minutes.

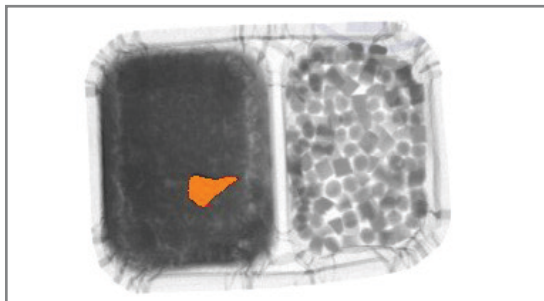

### Reliable Metal and Contaminant Detection in Foil Trays

With a rectangular inspection window, the system detects all metal types, bone, glass or dense plastics, even inspecting products packaged in foil trays or metalized film.

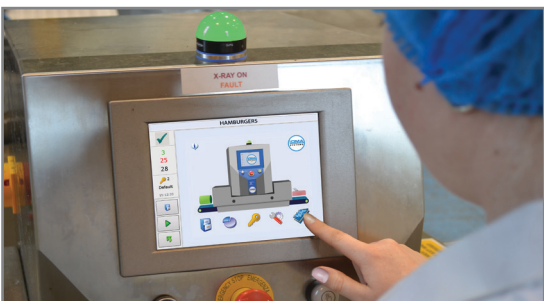

### Designed with New Users of X-Ray in Mind

A simplified yet powerful inspection feature set, plug and play installation, reliable inspection and low cost of ownership make the X5C an ideal choice for those switching to X-Ray for the first time.

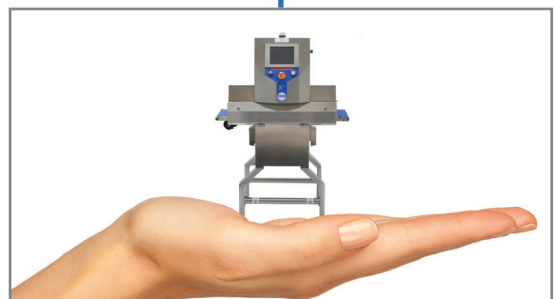

### Compact System Optimises Valuable Space

The X5C is built with Loma's strong experience of food industry inspection systems and offers first-class CCP protection in the smallest footprint possible.

# Technical Specification

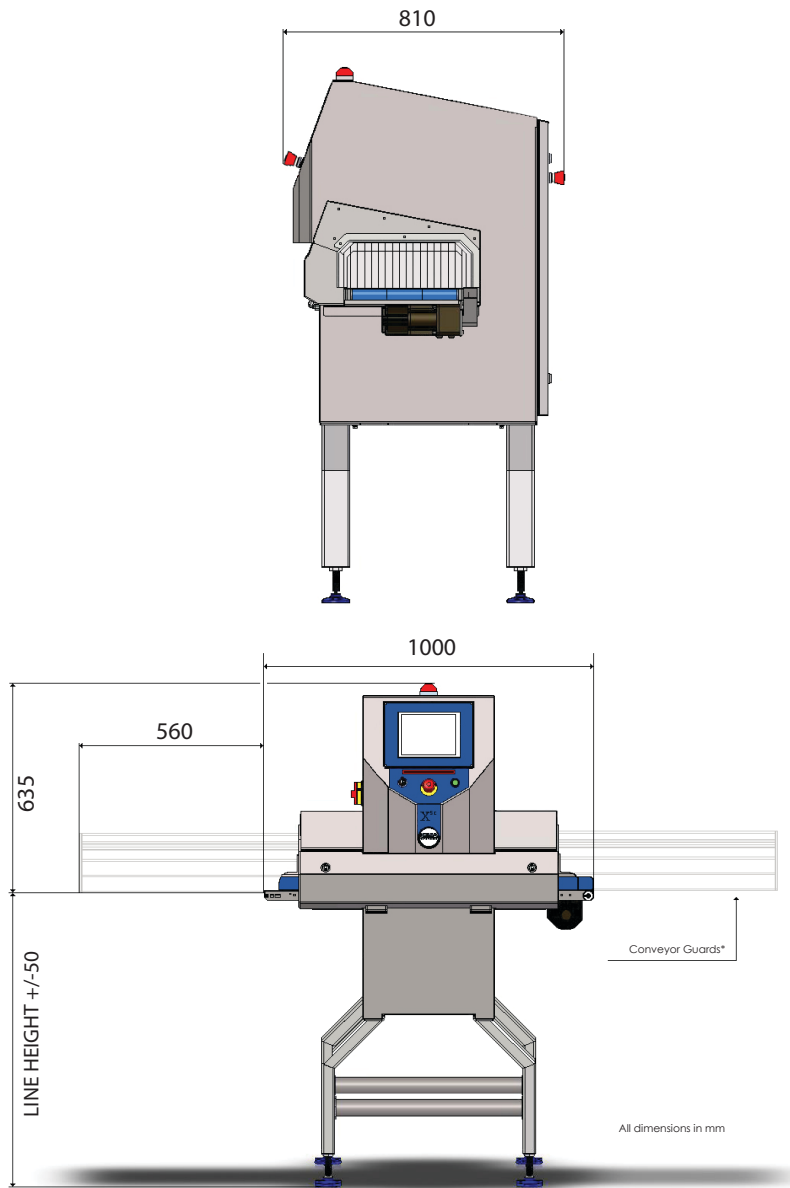

Finish	304 stainless steel
System Length	1000 mm (machine only) 1800 mm (with optional auto-reject)
Line Height Option	750 - 1000 mm ( $\pm 50$ adjustment)
Product Height (recommended maximum)	110 mm
Product Width (recommended maximum)	280 mm
Product Length (recommended maximum)	280 mm
X-Ray Output	80W (40 kV 2 mA)
IP Rating	IP66
Belt Width	300 mm
Belt Type	PU Anti-Static
Weight on Belt	Up to 6 kg**
Speed Range	10 - 50 m/min
Power Requirements	220-230 V, 50Hz or 110-120 V, 60Hz, Single Phase Mains
Operating Environment	2 to 10 °C with cabinet warm up, 10 to 35 °C with Vortex
Cooling	Vortex
X-Ray Safety	Leakage less than 1 $\mu$ Sv/h
Machine Weight	160 kg
Detection Algorithms	2 x contaminant 3 x object checking 2 x image optimisation
Reporting	Event, Batch, Shift
Data Retrieval	via USB

\*Although the machine installation requires a line length of 1000 mm, the system is supplied with extended covers to prevent limb access into the x-ray chamber and provide compliance with the Machinery Directive. During installation the extended covers should be fitted or equivalent protection be provided by other inline equipment (e.g. a reject conveyor) or guarding on both the infeed and outfeed. \*\*Maximum recommended weight is around 3 kg; at faster speeds it may be possible to go up to 6 kg.

## Automatic Reject Options

The X5C is supplied as standard with two output signals suitable for triggering third-party reject systems. Alternatively, it can be specified with an automatic reject station (with retail compliance) with the following options:

- Pusher
- Air-blast, single nozzle
- Air-blast, dual nozzle



An ITW Company

Loma Systems is a registered trademark of Illinois Tool Works Inc. (ITW). Other names, logos, icons and marks identifying our products and services referenced herein are trademarks of ITW and may not be used without the prior written permission of ITW. Other product and company names listed are trademarks or trade names of their respective companies. Copyright © 2016 Illinois Tool Works Inc. All rights reserved. All of the specifications shown in this document are subject to change without notice.

[www.congnghekiemtra.vn](http://www.congnghekiemtra.vn)

Hotline: 0907 686 889 | Email: [hoanglongtechnology@gmail.com](mailto:hoanglongtechnology@gmail.com)

**Metal Detection | Checkweighing | X-Ray Inspection**

In association with



X5Cmk2\_893201703