



# IQ4 - Metal Detection Conveyor

Designed for Food & Packaging Industries

## Product Highlights

- With significant improvements in signal processing, the new Auto-Learn rapidly delivers excellent detection sensitivities out of the box and provides more line uptime than ever before
- Variable-frequency detection (31 to 882 kHz)
- Full range of aperture sizes to suit products being inspected
- Multiple product memories for rapid product change over and data storage
- Graphical DDS vector display and PVS improvements help increase the usefulness of the IQ4 series
- Multilevel password protection provides secure access



### 7" Color Touchscreen with Engaging New User Interface

Standard across all of the IQ4 range, the big 7" touchscreen offers 33% more space than previous generation metal detectors and makes light work of setting, running and minimalising user errors

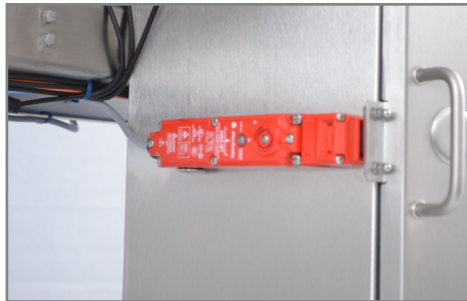

### Full Retail Compliance

Systems comply with strict international standards such as IFS, BRC, and FSMA; and can also be supplied with "Higher Level Compliance" functionality to meet the strictest of Retailer Codes of Practice



### Robust "Beyond" IP69K Rating

An improved lip, screen, and new blue sealing arrangement, combined with ultra-harsh mechanics proven from the IQ3+ range, make this one of the toughest and factory-friendly metal detectors on the market



# Technical Specification

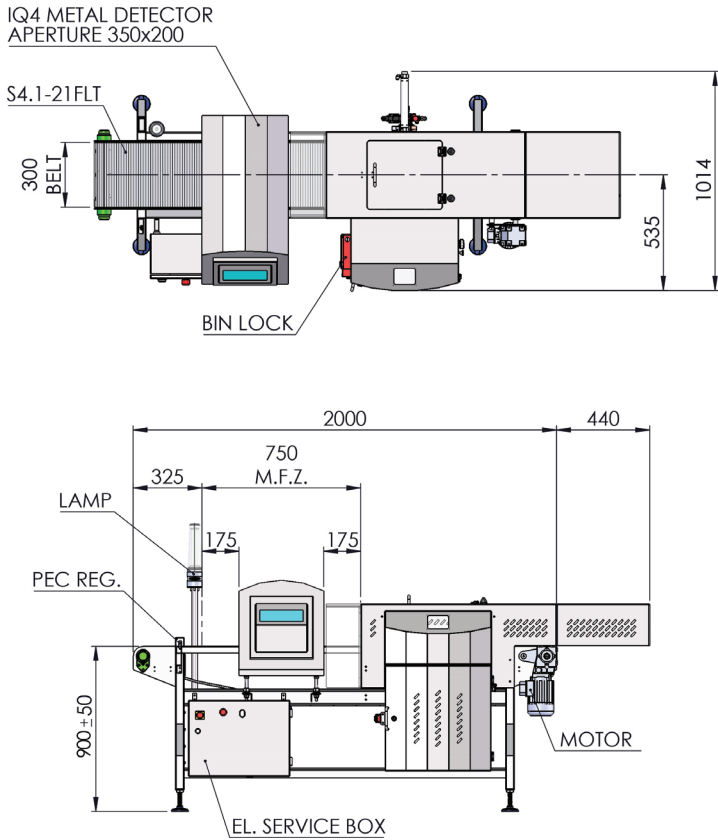

Example Model pictured: IQ4 With Full Retail Compliance, sizes shown in mm

Material of Construction	304 Brushed stainless steel
True Variable Frequency	31 to 882 kHz
Supply Voltages	85 to 265 V, single phase 50/60 Hz, neutral & Earth
Power Consumption	~700 VA
Temperature Range	-10 to +40 °C (14 to 104 °F)
Humidity	0 to 95 % Relative Humidity (Non-condensing)
IP Rating	IP66 (Head IP69K)
PVS Enabled	Yes
Ethernet Capability	Yes
USB Capability	Yes
Compliance Levels	SOD, Auto Rejection, Retail, Full Retail.

## Automatic Reject Options

The IQ4 Metal Detector Conveyor can be configured to suit a variety of different product applications. It is available in various configurations including:

- Belt-Stop / Stop On Detect
- Pusher
- Air-blast, single nozzle
- Air-blast, dual nozzle

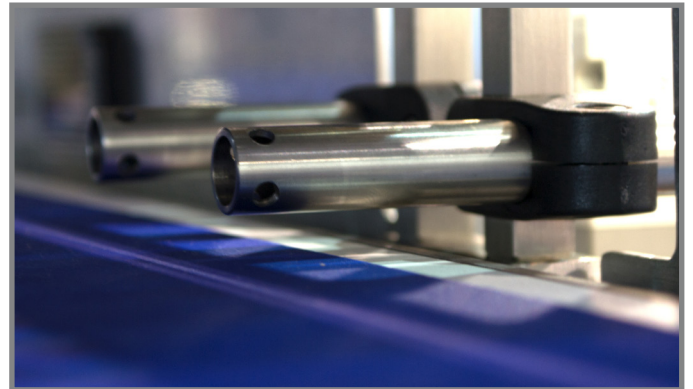

An ITW Company

[www.congnghehoanglong.com](http://www.congnghehoanglong.com)

Tel: 028 3839 8999 | Hotline: 0907 686 889 | Email: [info@congnghehoanglong.com](mailto:info@congnghehoanglong.com)

**Metal Detection | Checkweighing | X-Ray Inspection**

Loma Systems is a registered trademark of Illinois Tool Works Inc. (ITW). Other names, logos, icons and marks identifying our products and services referenced herein are trademarks of ITW and may not be used without the prior written permission of ITW. Other product and company names listed are trademarks or trade names of their respective companies. Copyright © 2017 Illinois Tool Works Inc. All rights reserved. All of the specifications shown in this document are subject to change without notice.

In association with

