



Metal Detection

Insight Pharmaceutical

Best-in-class out-of-box detection for all types of metal fragments. The height adjustable frame with robust clamping sleeve allows for easy integration with all leading tablet presses and encapsulation machines.



Insight Pharmaceutical metal detector with DDS.



The Insight Pharmaceutical metal detector is GMP compliant and offers exceptional stability to extreme vibration and product signal.

- 30,000 units/min throughput
- Compliant with 21 CFR parts 210 and 211
- IQ, OQ and PQ validation and certification
- Independently ATEX approved
- IP66 / NEMA 4X
- Wired or wireless ethernet
- External USB port
- OPTIX software with DDS vector diagram
- Stainless steel construction
- Automatic product learn
- 200 product presets
- Stores 8,000 data events



www.congnghehoanglong.com | 0907 686 889



METAL DETECTION | INSIGHT PHARMACEUTICAL

OPTIX Software is a powerful diagnostic and problem solving tool for engineers and operators. The user-friendly touchpad features multiple language options and DDS (Direct Digital Signal) vector diagram display. The unique DDS vector diagram display generates a detailed product profile needed to achieve perfect product set-ups.

Ongoing Service Realize the maximum uptime from your inspection systems by relying on the industry's foremost technical experts. Get best-in-class service when and where you need it.

- Onsite repair
- Remote diagnostics and support
- Planned and preventative maintenance
- Spare parts and kits
- Full systems integration
- Refurbishments
- Quality assurance and compliance

Insight Pharmaceutical Metal Detector Drawings

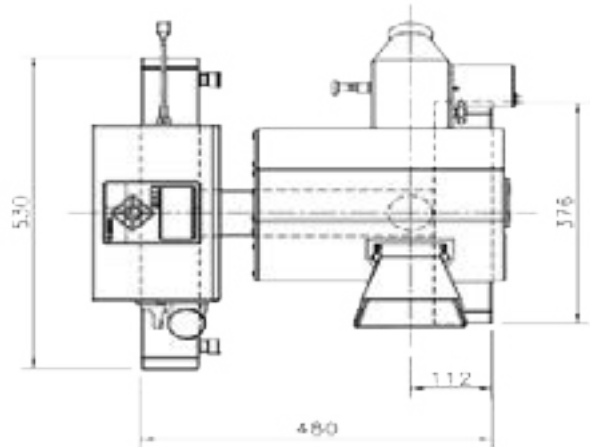
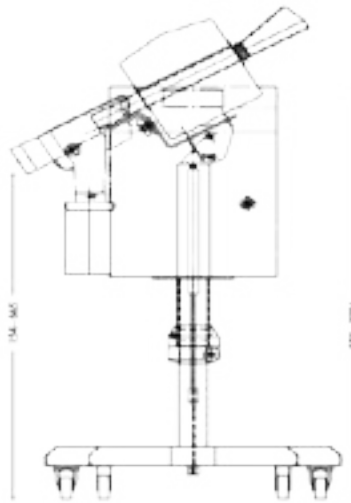

	Insight Pharmaceutical
Finish	316 stainless steel with mirror polish finish
Std Head Size	95mm x 22mm and 95mm x 38mm
Supply Voltages	230V or 120 1ph / N+E 50 or 60Hz
Throughput	30,000 units/min
Accuracy	0.22 Fe, 0.28 NFe, 0.37 SST (optimized)
Reject Options	Lift-flap, Diverter, Wash-in-Place, Dust-Tight
Connectivity	Wired or wireless ethernet and SCADA capability; external USB port
Power Requirements	99-264V AC, 47-63Hz, Fuse 3A
Protection	IP66 / NEMA 4X
Environment	-10° to 40° C / 23° to 104° F; Humidity 0-95% RH
Features	200 product memory, 8,000 data events memory, four-level password protection, touchpad, OPTIX software, DDS, fail safe operating mode, automatic balance, reject bottle, infeed chute, test samples, lockable casters, lockable cabinet, USB port
Options	4-zone light stack, audible alarm, IQ/OQ/PQ validation package, high-line height, wired or wireless ethernet

© 2014. Loma Systems. All rights reserved. Loma Systems is a registered trademark of Illinois Tool Works, Inc. (ITW). Other names, logos, icons and marks identifying Loma Systems products and services referenced herein are trademarks of Loma Systems and may not be used without the prior written permission of Loma Systems. All of the specifications shown in this document are subject to change without notice.



Hoang Long Technology Co., Ltd.
 468 Le Hong Phong, Ward 1, District 10, HCM City, Viet Nam
 Tel: +84 (0) 8383 98999 Fax: +84 (0) 8383 98777
 Hotline: 0907 686 889
 Email: info@congnghehoanglong.com
 Website: congnghehoanglong.com