



# Insight Vertical Fall - Metal Detection System

Designed for the Food Industry

## Product Highlights

- Gravity feed system for inspecting powders or granules
- Supplied complete with frame, throughput tube and choice of sealed valve or cowbell reject devices
- Tivar anti-static food grade throughput tube as standard
- Air failure and dump valve features included
- Four password protected security levels are provided for Operators, Supervisors, Engineering and Administration

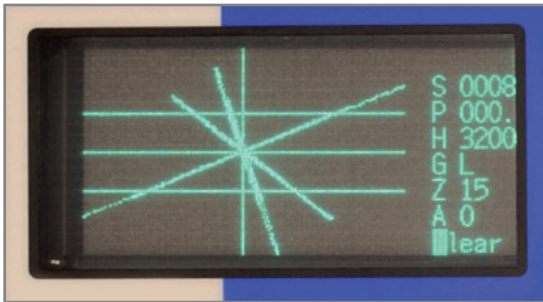

### DDS Vector Display Delivers Perfect Product Set-ups

The Direct Digital Signal (DDS) vector display provides a graphic representation of the metal detection process, aids perfect product set-up and is an excellent diagnostic tool.



### Auto Learn Provides Simple and Fast Set-up

The Insight VF will automatically set-up and store 200 different pre-sets, calibrating for product effect and loose material as the product passes through the system.



### External USB Port for Data Reports

Each unit is supplied with an external USB port to download data for secure storage and distribution in pdf or other formats. Wired or wireless ethernet and SCADA capability are available.

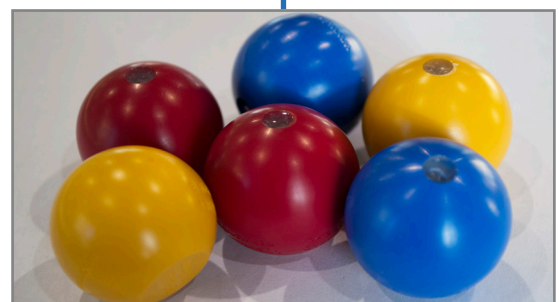

### Best in Class Detection Levels for Magnetic and Non-magnetic Metals

The Insight VF offers excellent detection levels of up to 0.6FE, 0.7NFE and 0.8StSt.

# Technical Specification

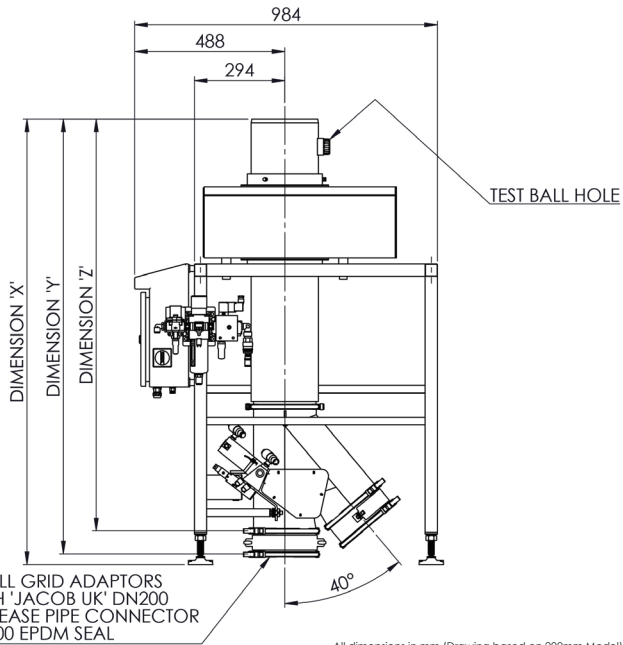
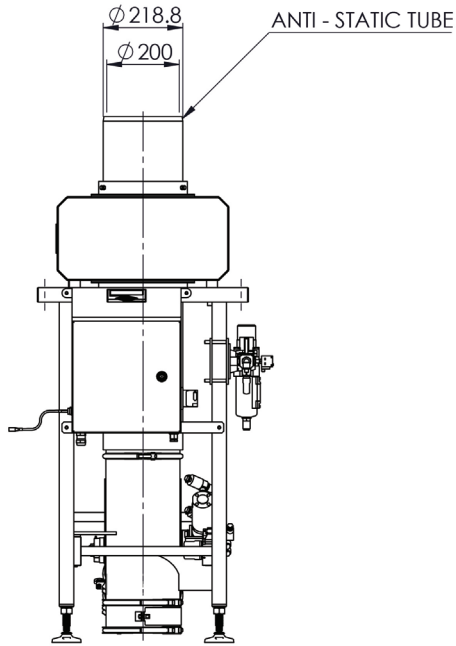

All dimensions in mm (Drawing based on 200mm Model)

Material of Construction	304 Brushed stainless steel
Available Frequencies	Single Freq 100KHz, 286KHz or 875KHz
Supply Voltages	110 - 250V AC 50/60Hz
Power Consumption	20VA
Temperature Range	-10°C TO 40°C (14°F to 104°F)
Humidity	0 to 95% Relative Humidity (Non-condensing)
Environment	IP66
PVS Enabled	Yes (Sample Test)
Ethernet Capability	Yes
USB Capability	Yes

HEIGHT OPTION	DIMENSION 'X'	DIMENSION 'Y'	DIMENSION 'Z'	MAXIMUM FALL HEIGHT
STANDARD	1447	1412	1337.5	900
SHORT	1243	1208	1133.5	200

## Automatic Reject Options

The Insight VF is supplied as standard with either of the below reject options:

- Sealed Valve
- Cowbell



[www.congnghehoanglong.com](http://www.congnghehoanglong.com)

Add: 468 Le Hong Phong street, ward 1, district 10, HCMC, VN

Tel: +84(8)38.398.999 - Hotline: +84(0)907.686.889

Email: [info@congnghehoanglong.com](mailto:info@congnghehoanglong.com)

In association with

