

THS/PL21 SERIES

Quality Control at its finest



PIPELINE INTEGRATED SYSTEMS WITH METAL DETECTOR AND EJECTION VALVE

FEATURES

- State-of-the Art Quality Control of liquid, viscous products and meat
- Detection and ejection of magnetic, non-magnetic and stainless steel metal contaminants
- Very high sensitivity. Multi spectrum technology available
- Fast detection and rejection speed
- Fail-Safe Operations
- Structure and components in AISI 316L stainless Steel and food-compatible plastics (EU, FDA compliant)
- Rugged, IP65/66/69 construction
- Easy to disassemble and clean



Fully HACCP and GMP compliant

THS/PLVM21

Pass-through with ejection valve integrated system for applications on meat vacuum filler machines.



www.maydokimloaiceia.vn



Hotline: 0907 686 889 - Email: hoanglongtechnology@gmail.com

CEIA reserves the right to make changes, at any moment and without notice, to the models, their accessories and options, to the prices and conditions of sale

CEIA is a manufacturing company specialized in the design, engineering and production of Metal Detectors.

The CEIA Integrated Systems are **especially designed for the inspection of liquid, and viscous products** and the elimination of any contaminating metals, whether magnetic, non-magnetic or stainless-steel.



The CEIA integrated systems are especially designed for metal contaminant detection in products transported by pipeline especially meat, soup, preserves...

The carefully selected materials used in construction do not interact with food products, and thus do not modify or alter their composition. The design of these systems incorporates a fast reject valve drive response time to detect and reject the contaminant without slowing down the product flow.

The construction guarantees quick, easy cleaning of the components that are in contact with the product. The technological choices made by CEIA allow the parts in contact with the product to be disassembled and maintained in a short time.

The systems operate in fail-safe mode, thus avoiding the risk of contaminants passing through even when the system is deactivated or when the electrical power supply is interrupted.

MULTI-SPECTRUM TECHNOLOGY

Exclusively developed by CEIA, this is **a unique metal detection technology that both optimizes sensitivity to all metal contaminants and minimizes product effect in a very wide range of possible products.**



By recognizing the different frequency response of conductive products and metals, this innovative technology cancels product effect and maintains high performance levels for all types of metal contaminants, both magnetic and non-magnetic.

The autolearn function used by CEIA Multi-Spectrum metal detectors equates to the repetition of hundreds of conventional transits. It explores the whole spectrum of available frequencies in order to determine the best operating conditions resulting in unique detection performance.

PIPELINE INTEGRATED SYSTEMS WITH METAL DETECTOR AND EJECTION VALVE



THS/PL 21 SERIES

INTEGRATED SYSTEM WITH METAL DETECTOR FOR LIQUID AND VISCIOUS PRODUCTS



THS/PLV 21 SERIES

INTEGRATED SYSTEM WITH METAL DETECTOR AND EJECTION VALVE FOR LIQUID AND VISCIOUS PRODUCTS



THS/PLVM 21 SERIES

INTEGRATED SYSTEM WITH METAL DETECTOR AND EJECTION VALVE FOR MEAT

THS/PL21 SERIES

PASS-THROUGH INTEGRATED SYSTEM FOR LIQUID AND VISCOUS PRODUCTS



FEATURES

- Detection of magnetic, non-magnetic and stainless steel metal contaminants
- Very high sensitivity. Multi spectrum technology available
- Standard pipe sizes available to suit all applications
- AISI 316L stainless steel construction to IP66 and IP69K protection levels
- High immunity to environmental interference
- Control Panels are listed according to UL 508A and CSA-C22.2 No. 14-05
- Easy to clean and inspect
- Minimum installation space required
- Wide range of flanges available for connection to bagging and clipping machines



THS/PL21E, THS/PLMS21, THS/PLH21E and THS/PLHMS21 models

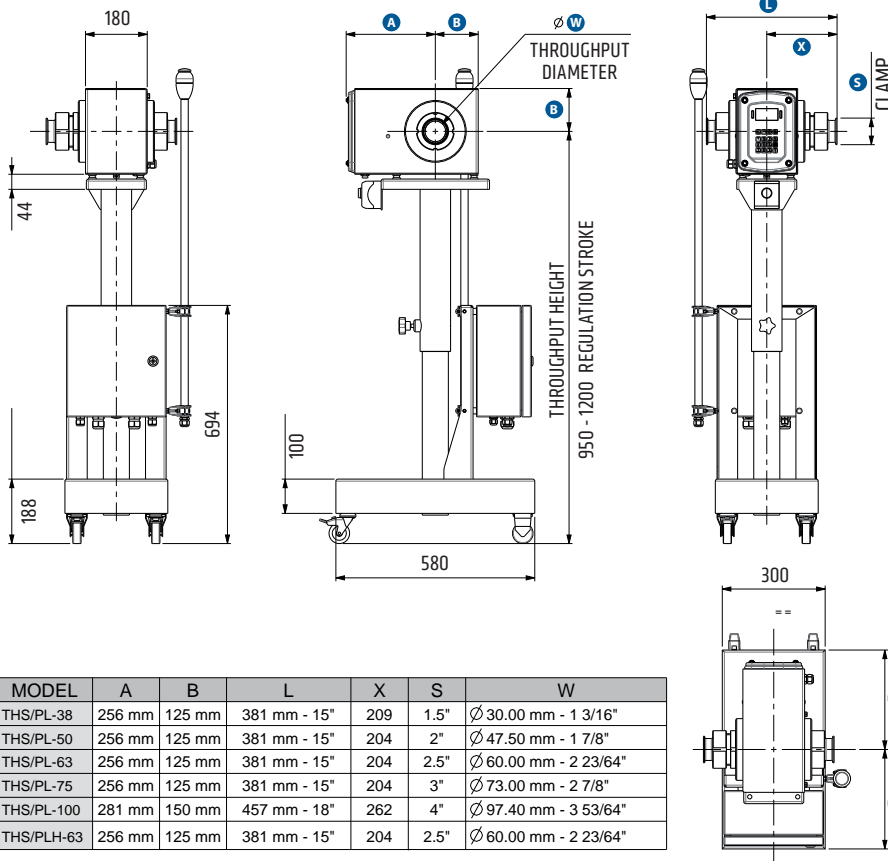

THS/PLMS21 designed for metal contaminant detection in products transported by pipeline.

THS/PLH21 (above) with integrated twisting extension kit.

Dimensions in mm

THS/PLV21 SERIES

PASS-THROUGH WITH EJECTION VALVE INTEGRATED SYSTEM FOR LIQUID AND VISCOUS PRODUCTS

FEATURES

- Detection and ejection of magnetic, non-magnetic and stainless steel metal contaminants
- Very high sensitivity. Multi spectrum technology available
- Standard pipe sizes available to suit all applications
- Fast acting reject device for a limited quantity of rejected product
- Control Panels are listed according to UL 508A and CSA-C22.2 No. 14-05
- Wide range of flanges available for connection to bagging and clipping machines
- Easy to clean and inspect
- Minimum installation space required
- Very High Reliability
- Maximum Operator Safety



THS/PLV21E and THS/PLV21 models

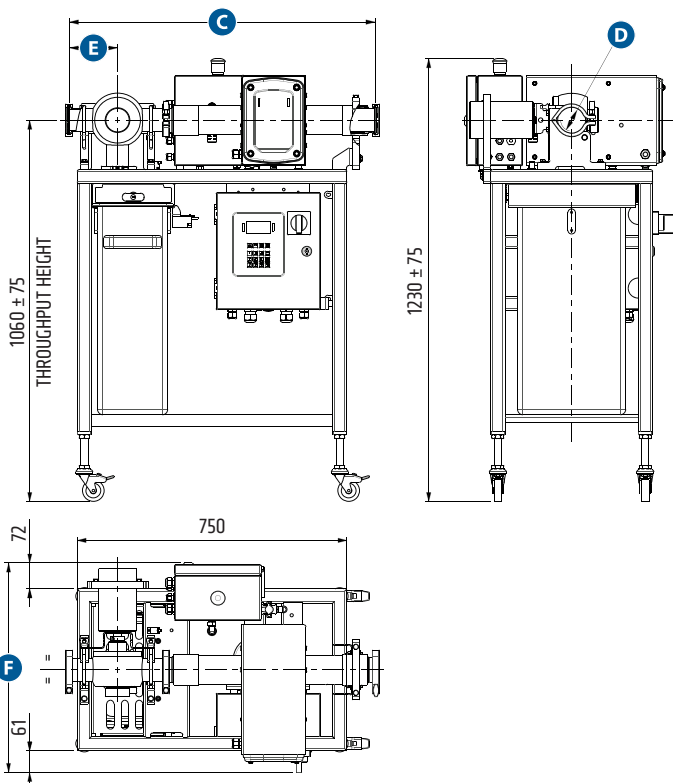

Model	C	internal diameter D	E	F
THS/PLV21-38 THS/PLV21E-38	843	38	167	583
THS/PLV21-50 THS/PLV21E-50	847	50	167	583
THS/PLV21-63 THS/PLV21E-63	850	60	134	583
THS/PLV21-75 THS/PLV21E-75	828	73	123	629
THS/PLV21-100 THS/PLV21E-100	1092	100	177	652

Dimensions in mm

PRODUCT TRANSIT PIPE FEATURES

- FDA and EC 1935/2004 compliant
- High resistance to food industry C.I.P.
- Flanges integrated with pipe for best cleanability

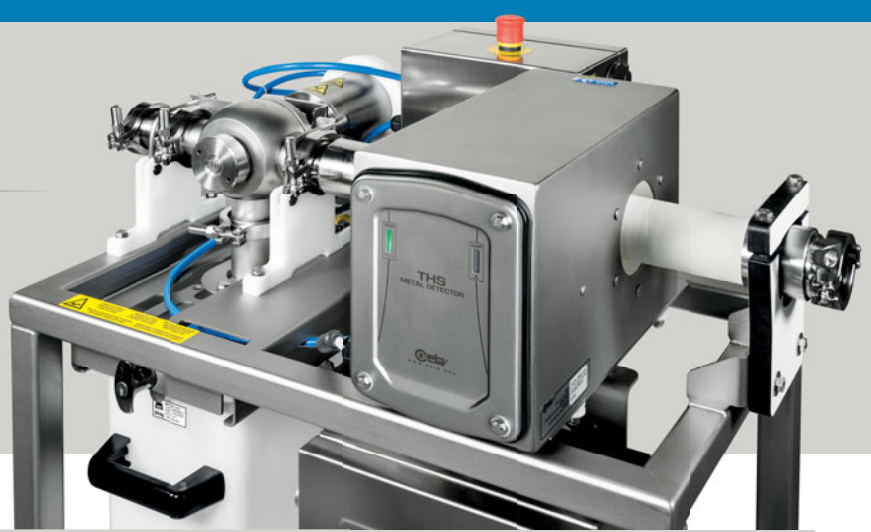

THS/PLV21E-C and THS/PLV21-C models

The system has been specially designed to be mounted on custom structures, without the rejected material bin.

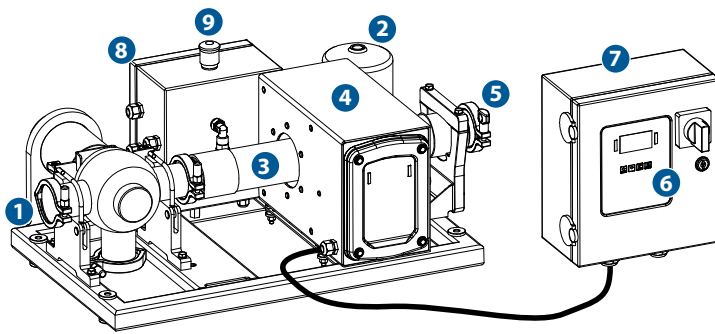

1	Inspected product exit
2	Pneumatic valve ejector
3	Product conveyor tube
4	Metal Detector probe
5	Product entrance
6	Control panel
7	Power-supply and control unit, for connecting the device to mains power and to the external supports
8	Pneumatic box
9	Emergency stop

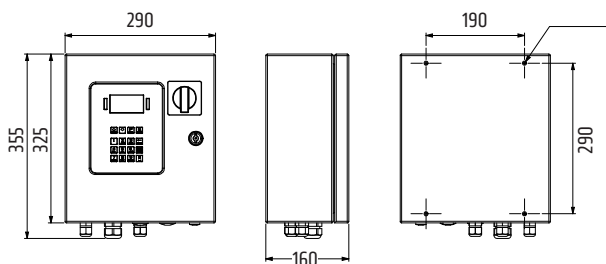
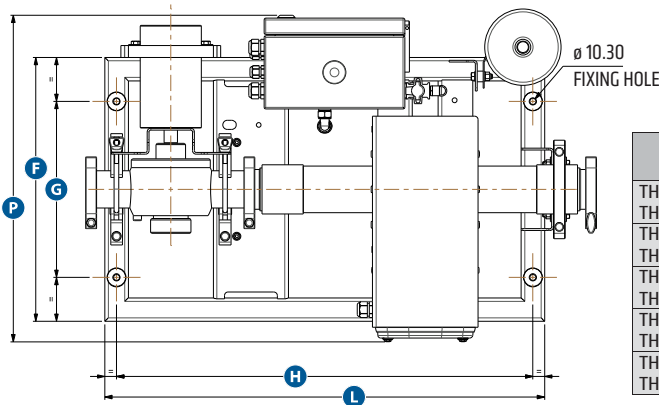
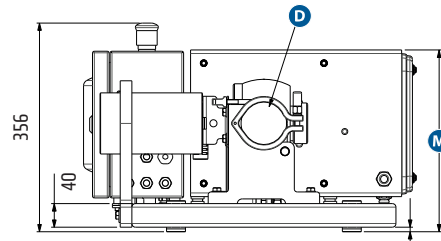
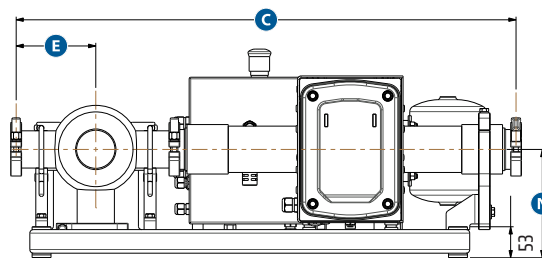

Model	C	int. σ D	E	F	G	H	L	M	N	P
THS/PLV21-38C	842	38	167	450	300	710	750	310	185	557
THS/PLV21E-38C										
THS/PLV21-50C	845	47.5	167	450	300	710	750	310	185	557
THS/PLV21E-50C										
THS/PLV21-63C	852	60	136	450	300	710	750	310	185	557
THS/PLV21E-63C										
THS/PLV21-75C	844	73	124	450	300	710	750	310	185	601
THS/PLV21E-75C										
THS/PLV21-100C	1091	100	177	500	350	910	950	360	210	651
THS/PLV21E-100C										

Dimensions in mm

THS/PLVM21 SERIES

PASS-THROUGH WITH EJECTION VALVE INTEGRATED SYSTEM FOR APPLICATIONS ON MEAT VACUUM FILLER MACHINES

FEATURES

- Detection and ejection of magnetic, non-magnetic and stainless steel metal contaminants
- Very high sensitivity. Multi spectrum technology available
- Standard pipe sizes available to suit all applications
- AISI 316L stainless steel construction to IP69K protection level
- High immunity to environmental interference
- Fast acting reject device for a limited quantity of rejected product
- Easy to clean and inspect
- Minimum installation space required
- Very High Reliability

The THS/PLVM21 series is design to operate in Harsh conditions

- Use of high pressure levels
- High risk of impact during movement and handling operations.
- Strong vibration working conditions due to the filler and clipper machines
- Hard wash down conditions



Alarm signalling

High-visibility LED with IP69K water protection. The cap is completely filled with resin, which ensures mechanical resistance and water tightness.

Reset and emergency button

Integrated in a Stainless Steel waterproof box in order to reduce possible effects of dirt and to protect electrical cables which could be damaged during cleaning.



The THS/PLVM21 series is designed for metal contaminant detection in products transported by pipeline especially meat.

The technological choices made by CEIA allow the parts in contact with the product to be disassembled and maintained in a short time.

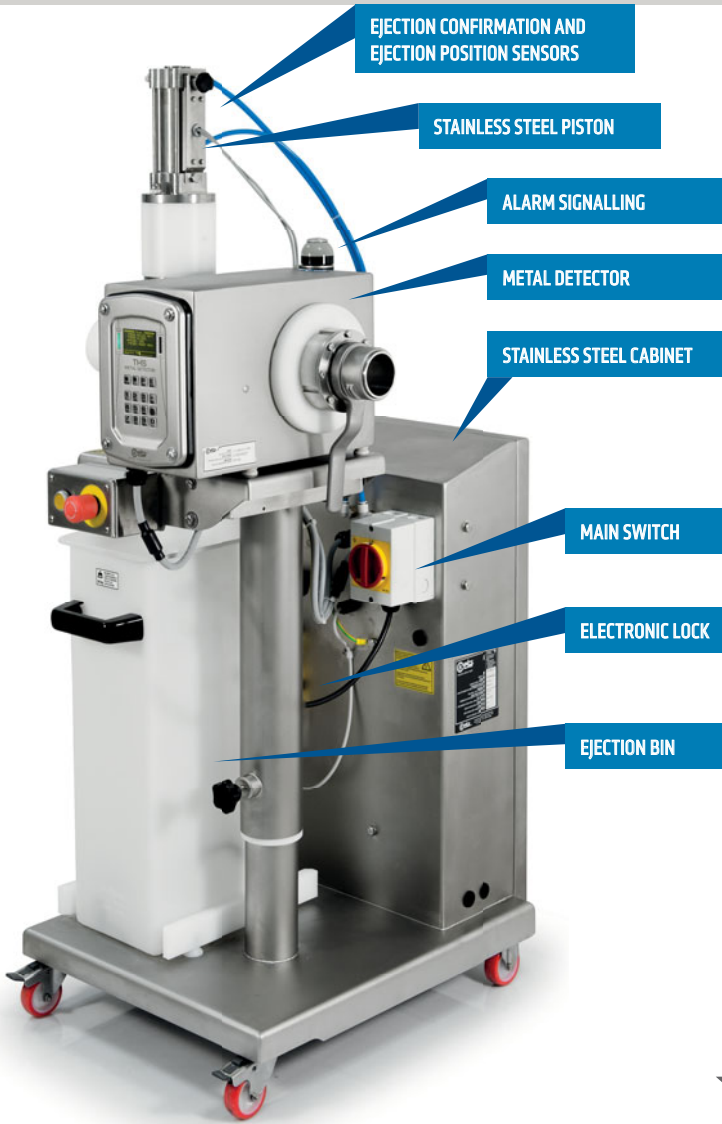

THS/PLVM21E and THS/PLVM21 models

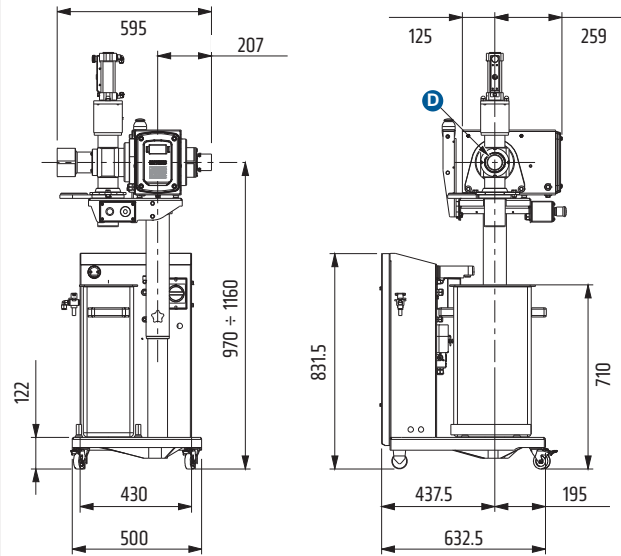

Model	internal diameter D	Dimensions in mm
THS/PLVM21-63 THS/PLVM21E-63	63	

LOCAL AND ADVANCED CONNECTIVITY [optional]



Stainless steel cabinet

Completely watertight, the cabinet protects both pneumatic and electronic components. The smooth surface facilitates cleaning procedure.



Stainless steel piston

SPECIAL FEATURES

	THS/XX21E	THS/XX21
Detection sensitivity	High	Ultra High
Immunity to environmental interference	High	High
Data display type	Alphanumeric OLED - 4x20 characters	High-contrast graphical OLED 128x64 pixels
Local programming	4 keys, 3 with double function	16 keys, 3 with double function
Control Power Box or Conveyor Control System according to Standards UL 508A and CSA-C22.2 No. 14-05	on request	on request
Construction compliant with 21 CFR Parts 210 and 211		
All parts in contact with the product are in FDA approved materials for food contact		
Audio and visual detection indicators		
Display of the signal level by means of bar graph		
Inspected/contaminated product counter		
Autolearn and automatic tracking of the product effect		
ISO 9001 certified manufacturer		

DATA MANAGEMENT

Management of electronic production data and electronic signatures as per CFR 21, Part 11

Data security / Data integrity / Data traceability

EVENTS STORAGE

Complete monitoring of occurred events

Ejections / Test results / Programming accesses / Programming operations / Faults

I/O INTERFACES

RS232, Auxiliary RS232, Bluetooth, Ethernet interface (on request), Wi-Fi and USB (on request)

SIGNALLING

Acoustic	Via internal buzzer
Optical	Graphic display with bar-graph indication
	Light indicators on control unit: RED: Alarm or Fault / GREEN: Power on

PROGRAMMING

Local: built-in keyboard and high-contrast display

Remote: through computer connected via Bluetooth, RS232, Ethernet or WiFi and managed with CEIA MD Scope software, THS Production Plus software or any other terminal emulation program or through Web Server (with optional IXC card)

SAFETY AND SECURITY

Protection degree	THS/XX21E	IP65
	THS/PLV21X and THS/PLVM21X	IP66 – IP69K
	On UL versions, the Control Power Box and Conveyor Control System have a 4X-12 certified degree of protection	
Electrical insulation	Galvanic isolation of the mains voltage	
	Compliant with international standards for safety and radio interference	
Acoustic emission	Acoustic pressure according to Directive 2006/42/EC: <70 dB(A); <130 dB(C)	
Pollution degree (IEC61010-1)	Class 2	
Installation category (IEC61010-1)	Category II	

SUPPLY

Control Power Box	Main voltage	100-240 VAC
	Frequency and phase	50/60 Hz - single phase
	Full load current (FLA)	2.2 A
Pneumatic system	Stainless steel waterproof container (protection degree: IP66 – IP69K)	
	Pressure	0.6 ÷ 1 MPa
	Flow	100 l/min

ENVIRONMENTAL CONDITIONS

Temperature	Operating	-10 to +55 °C
	Storage	-25 to +55°C (THS/PLV 21x - THS/PLVM 21x); 70°C for short periods, 24h max -40 to +70°C (THS/PL 21x)
Relative humidity	Operating / Storage	5 – 90 %, non-condensing

PRODUCT CONDITIONS

Maximum temperature (for higher temperatures, contact CEIA)	Product in transit	70°C (THS/PLV 21x) 60°C (THS/PLVM 21x)
	Inside the rejected material bin	70°C
Maximum allowed pressure (for higher pressures, contact CEIA)	Transit pipe	1 MPa (THS/PLV 21x - THS/PLVM 21x) 1 MPa with product up to 60°C (THS/PL 21x) 0.6 MPa with product up to 90°C (THS/PL 21x)



HOANG LONG TECHNOLOGY
Always for your product quality

HOANG LONG TECHNOLOGY CO., LTD
468 Le Hong Phong Str, District 10, Ho Chi Minh City
Tel: 028 38 398 999; Hotline: 0907 686 889

REPRESENTATIVE OFFICE IN DA NANG
172 Ngo Huy Dien Str, Hoa Xuan, Cam Le District, Da Nang City
Tel: 0236 3 628 688

Email: hoanglongtechnology@gmail.com
Web: congnghehoanglong.com or maydokimloaiceia.vn