

# THS/RB-800

## HIGH PERFORMANCE METAL DETECTION SYSTEM WITH ROUND BELT FOR IN-LINE APPLICATIONS

**CEIA introduces the new THS/RB-800 as the latest addition to the THS family.**

This is an innovative and unique system designed for seamless and highly compatible integration into standard checkweigher systems and other in-line applications, so that maximum detection sensitivity can always be achieved. The THS/RB-800 offers a high performance cost effective solution where space and best performance are critical.

### Main Features

- Compact conveyor system integrated with THS /SL21 series Metal Detectors
- Round belt design to eliminate metal contamination risk, thus achieving maximum sensitivity
- Hygienic and easy to inspect conveyor
- Conveyor skidplate and belt can be removed in seconds without tools for easy cleaning
- Digitally-adjustable belt speed, with the option of automatic synchronization with the following conveyor
- Fully compliant with HACCP criteria
- High immunity to environmental interference
- Very high sensitivity to all magnetic and non-magnetic metals, including stainless steel
- Multi-spectrum technology for the most accurate compensation of the product effect [MS21 series]
- Automatic learning & tracking of product effect
- Up to 500 product data memories, selectable by local programming or network software
- Up to 40 definable users with username and password



HOANG LONG TECHNOLOGY CO., LTD.

Hotline: 0907 686 889 - Email: hoanglongtechnology@gmail.com

[www.maydokimloaiceia.vn](http://www.maydokimloaiceia.vn)

CEIA reserves the right to make changes, at any moment and without notice, to the models (including programming), their accessories and options, to the prices and conditions of sale



**HOANG LONG  
TECHNOLOGY**

Always for your product quality

The new CEIA THS/RB-800 has been developed as a solution for seamless integration into any checkweigher system and other in-line applications. The main design considerations being a conveyor which allows the best sensitivity performance of the metal detector to be maintained throughout its lifetime.

At a length of 800 mm its footprint is small, and therefore it fits in the line taking up minimal space.

The simple electrical integration required allows the metal reject function to be carried out separately using the existing reject systems. Conveyor belt maintenance is minimal due to its unique design, which permits skidplate removal in seconds without the requirement for tools.

### Technical Specifications

Conveyor belt length	800 mm
Conveyor belt width	200/300/400 mm
Conveyor belt height	875 mm +/- 50 mm
Variable Belt speed	20 - 60 m/min
Max weight on the belt	5 Kg
Usable aperture height	65/90/115/140/165 mm
Structure and components	AISI 304
Surface Finishing	Polished
Protection degree	IP54 (IP65 available on request)

Built-in encoder for following conveyor speed sensing

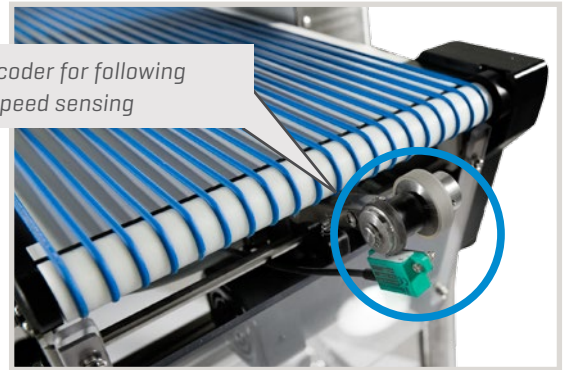

Round Polyurethane cord [FDA approved]



### Mechanical Dimensions [mm]

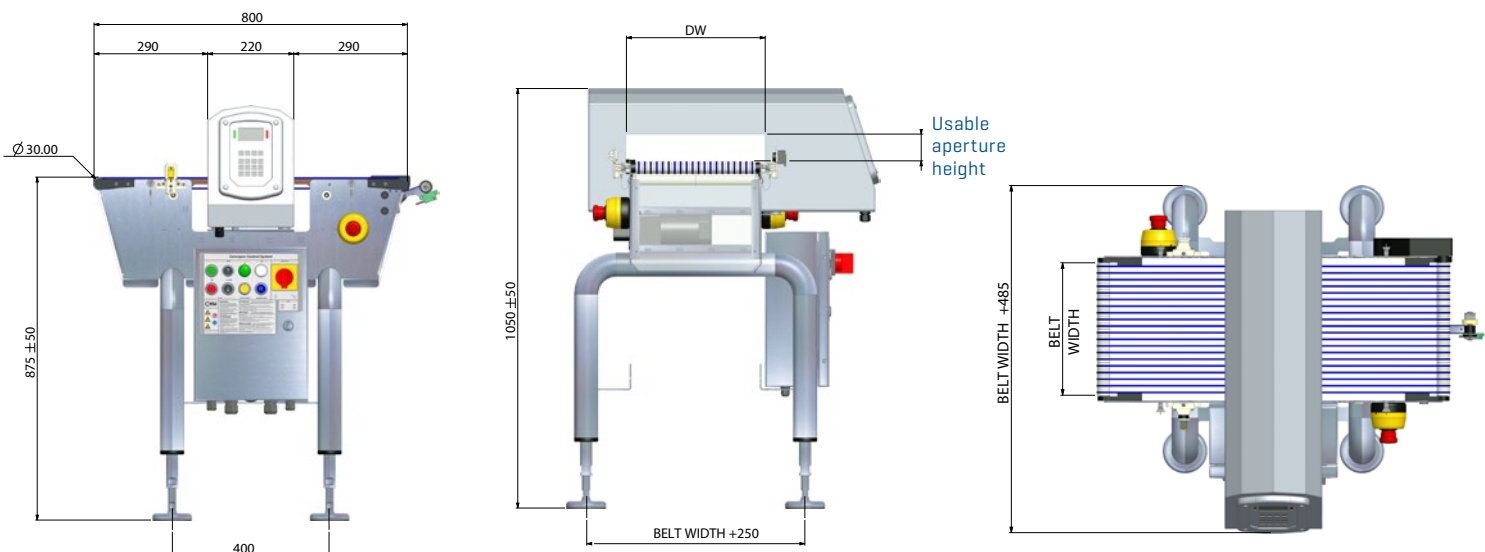

Easy to clean and maintain



#	TOOL-FREE BELT REMOVAL
1	Extract the four locking pins
2	Lift the belt and the skid plate
3	Remove the belt and the skid plate from the conveyor

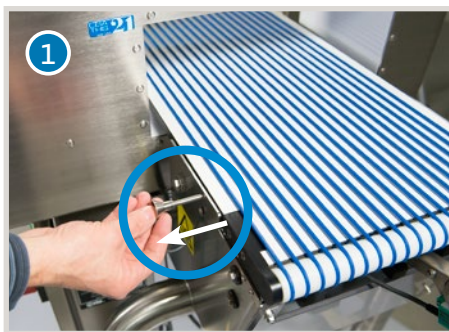

Examples of installation

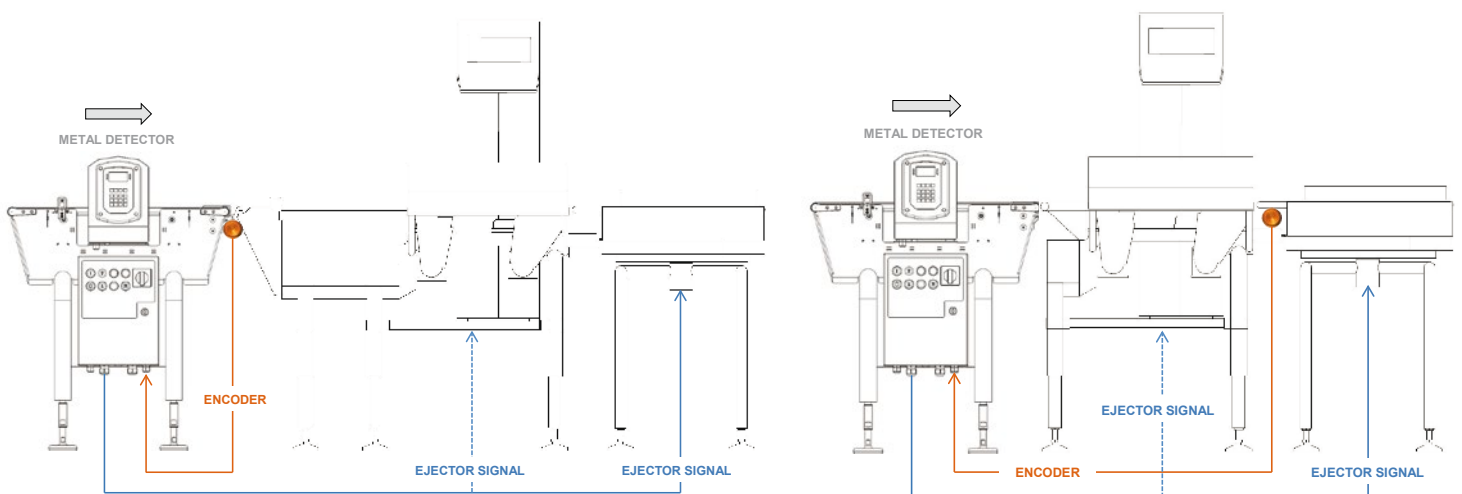

## THS/RB Round Belt Configuration

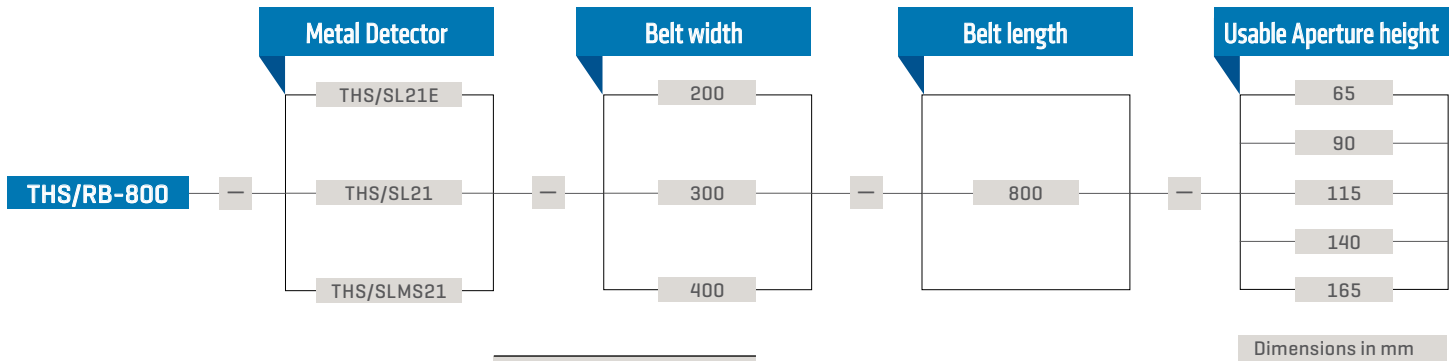

	THS/RB-X-X-800-X
Synchronization photocell	●
Variable speed	●
Ejection output relay signal	●
Built-in encoder for following conveyor speed sensing	○

Standard ●  
Option ○

## Specifications

GENERAL FEATURES	Conveyor belt integrated with Metal Detector	Easy to clean and maintain
	Full compliance with HACCP criteria	Multi-spectrum technology for most accurate compensation of the product effect
	Structure and components in stainless steel and food-compatible plastic parts (FDA, Usda compliant)	Very high sensitivity to all magnetic and non-magnetic metals, including stainless steel
	Control Panel listed according to UL 508A and CSA-C22.2 No. 14-05 available	Automatic learning and tracking of product effect
	Digitally-adjustable belt speed, with the option of automatic synchronization with the following conveyor	500 product data memories, selectable by local programming or network software
	High immunity to environmental interference	Up to 40 definable users with username and password
DATA MANAGEMENT	Electronic Records and Signatures Management compliant with 21 CFR Part 11: Data Security, Data Integrity, Data Traceability	
EJECTION SYSTEMS	Output relay to drive one ejector placed in the following conveyor	
POWER SUPPLY	100-120 Vac or 200-240 Vac, single phase - 50-60 Hz - 11.4A max	
CONTROL INPUTS	Downstream and upstream belt authorization	
ENVIRONMENTAL CONDITIONS	Operating temperature: 0°C to +50°C	
	Relative humidity: 5 to 90% (without condensation)	
DEGREE OF PROTECTION	Control System certified: Type 4X-12 (UL 50) available	
	Conveyor System: IP54 (IEC 529) - IP65 available on request	
SIGNALS	System completely monitored by self-diagnosis	
	Optical/acoustic signal for faults and alarms	
INTERFACE	RS-232 Serial interface	
	Bluetooth	
	Ethernet interface (on request)	
	WI-FI and USB (on request)	
MANAGEMENT SOFTWARE	THS Production software for statistical and operational management of networked THS systems	
	MD-SCOPE for local maintenance and programming operations	



HOANG LONG TECHNOLOGY CO., LTD.

Hotline: 0907 686 889 - Email: hoanglongtechnology@gmail.com

[www.maydokimloaiceia.vn](http://www.maydokimloaiceia.vn)

CEIA reserves the right to make changes, at any moment and without notice, to the models (including programming), their accessories and options, to the prices and conditions of sale



**HOANG LONG**  
TECHNOLOGY

Always for your product quality