

Segmentable Hi-Tec polymer Deduster/Deburrer PF - iSeries > PF 750 - iSeries

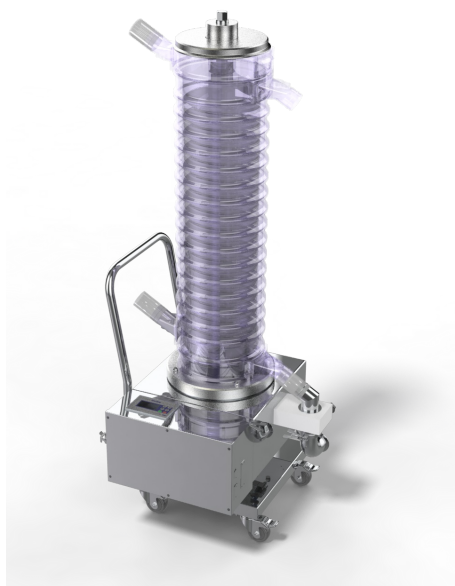

Like the original PharmaFlex range of Dedusters, each of the new PF - iSeries Deduster's spiral segments can be removed individually for easier cleaning and fast changeover.

Additional Description:

This modular system also allows adjustable height gain; additional segments can be added in increments of 5 to increase the machine's height and extend its shaft. A self-regulating vibratory base with accelerometer, making it unnecessary to adjust gaps of springs on the unit's base when changing the deduster's tower height, or when transitioning from one product to another. This unit allows to dedust tablets from 4 mm to 25 mm at a Hi-Speed. 5 different conveying heights are available from 500 mm to 1500mm. Enlarged circumferential dust extraction channel and central air jet on the tablets improve dedusting efficiency. A self-regulating vibrating base with accelerometer, making it unnecessary to adjust gaps of springs on the unit's base when changing the deduster's tower height, or when transitioning from one product to another. Clear spiral segments for the complete tower, providing direct sightlines to tablets throughout the process. Optional deburring modules are available. This "dust tight" technology allows a higher dedusting efficiency thanks to an innovative dust extraction in conjunction with an air jet system.

Product Information

Title	PF 750 - iSeries
Assembly Number	400 731 00

Product features

Products to process	tablets / effervescents
Dedusting technology	Vibrating Ascending Spiral
Air jet	No
Deburring option	No
Conveyor material	FDA Hi-Tec polymer
Capacity / Speed	Not available
Micro tablets Diam 2,5 mm	0
Small Tablets Diam. 5 mm	3000000
Medium Tablets Diam. 13 mm	500000
Effervescent Tablets Diam. 20 mm	150000
Small capsules T4	750000
Large capsules T0	300000
Interfacing / Connectivity	
Interlacing type	Standard
Inlet Height	736.0
Elevation Height	Not available
Outlet Height	1423.0
Total Height	1672.0
Accessories	
Metal check	No Metal Check
Diverter	No
Empty capsule eliminator	No
Tester	No

Regulations

Operator Exposure Level

Standard

Noise level

Not available

GMP compliance

Yes

CE compliance

Yes

Cleaning and Dismantling

Manual cleaning

Yes

Automatic cleaning

No

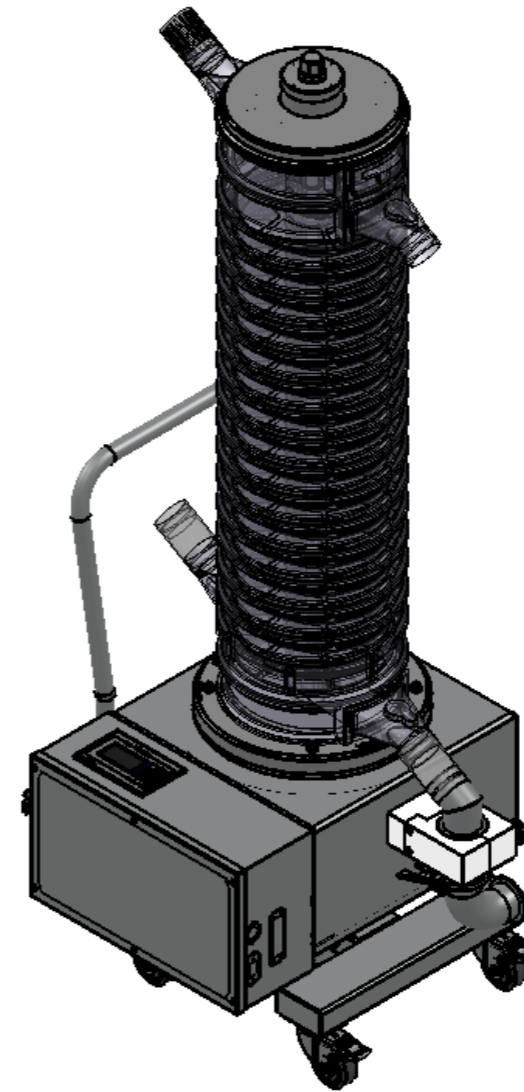
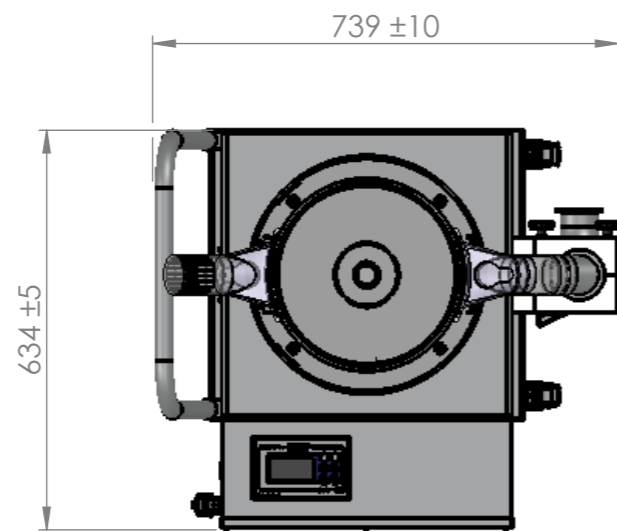
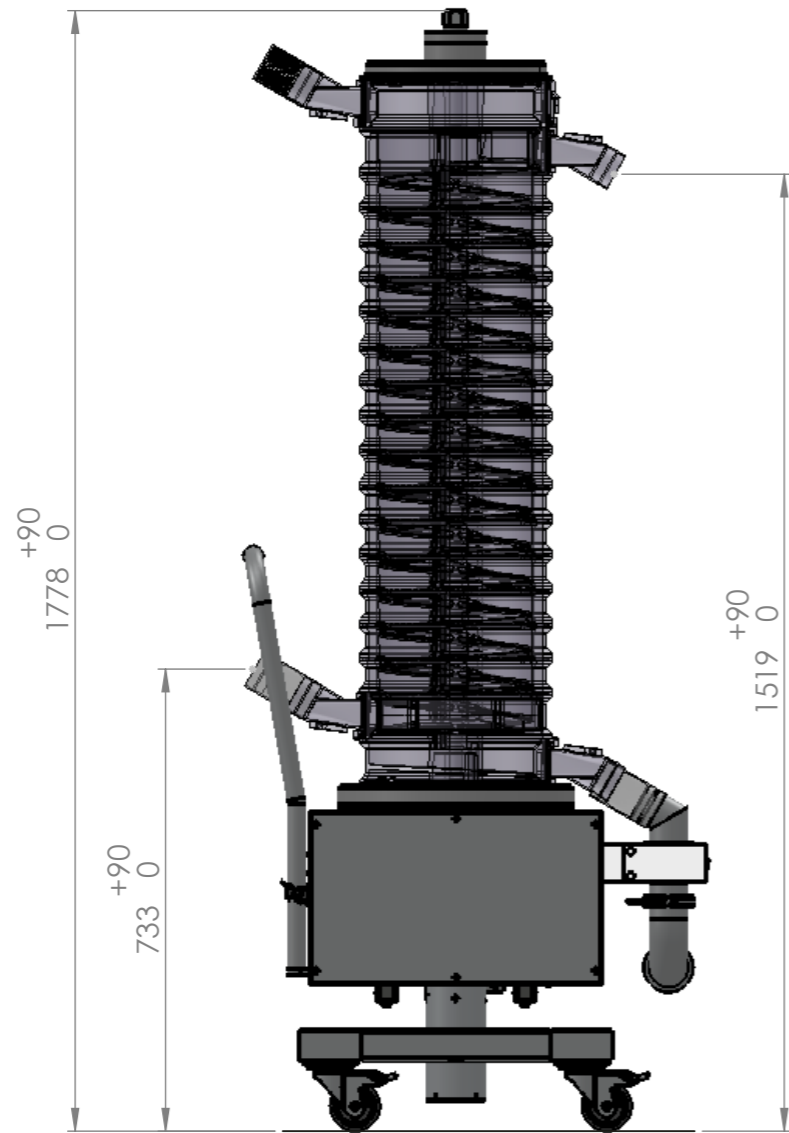

ACCEPTED

NAME :

DATE :

SIGNATURE :

Choose your power supply

110V - 230V

50Hz - 60Hz

PRJ 400 731 00 - PF 750

PHARMA TECHNOLOGY
PHARMA FLEX

THIS DRAWING IS THE PROPERTY OF PHARMA TECHNOLOGY & PHARMA FLEX. DELIVERY HEREOF IS MADE UPON THE UNDERSTANDING THAT IT WILL NOT BE COPIED IN WHOLE OR IN PART. THAT IT WILL BE RETURNED UPON REQUEST AND THAT THE INFORMATION AND DATA HEREIN CONTAINED WILL BE KEPT CONFIDENTIAL

REMARK

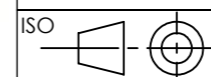

CREATION DATE
08/06/15

DWG
FCH

CHK
DHU

WEIGHT (kg)
N/A

FORMAT
A3

ISSUE
00

APPROVAL DATE
08/06/15

PROJECT N°
PRJ 400 731 00

REV

SCALE
1:12

SHEET
1/1

DESCRIPTION

PF 750

RUE DE LA MAITRISE 11 - B1400 NIVELLES - BELGIUM - WEBSITE: www.pharmatec.be